

NOTICE DE POSE

Espace d'angle Soleo



PRÉPARATION



x2



90 minutes

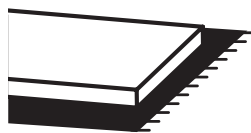

- Veillez à ce que le **sol** de l'emplacement soit de niveau.
- L'espace de montage doit être **propre** et **dégagé**, prévoir **3m x 3m** au sol.

OUTILS

NON FOURNIS :



Maillet

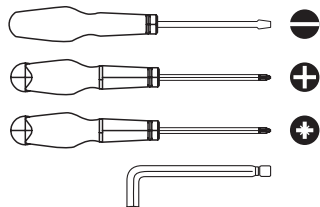

Tournevis et clé 6 pans



Visseuse



Perceuse

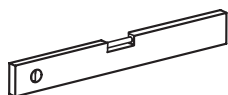

Niveau à bulle



Crayon



Eau savonneuse + chiffon

QUINCAILLERIE : composition des sachets



LES CHEVILLES ET VIS DE FIXATION AU MUR NE SONT PAS FOURNIS

Sachet pour joue n°825

A	équerre	x1
B	cache	x1
C	tourillon	x2
D	insert métallique	x4
E	goujon fil métal	x4
F	vis	x2

Sachet pour joue d'angle n°849

D	insert métallique	x8
E	goujon fil métal	x8
C	tourillon	x6

Sachet pour plinthe n°801

G	clip de plinthe	x2
H	support clip de plinthe	x2
F	vis	x4

Sachet pour tasseau n°832

S	vis	x6
----------	-----	----

Sachet pour tasseau d'angle n°846

D	insert métallique	x3
E	goujon fil métal	x3
K	excentrique*	x3
S	vis	x3

Sachet pour piétement tablette basse n°826

I	embase	x4
J	piéd	x4
F	vis	x16

Sachet pour tablette fixe n°827

K	excentrique*	x4
----------	--------------	----

Sachet pour tablette semi-fixe n°804

L	boitier	x4
M	goujon	x4

Sachet pour tablette semi-fixe d'angle n°847

T	goujon double	x2
C	tourillon	x2
L	boitier	x2
M	goujon	x2

Sachet pour tablette fixe d'angle n°848

T	goujon double	x2
----------	---------------	----

Sachet pour tringle n°828

P	support tringle	x2
F	vis	x2

Sachet pour tringle d'angle n°850

U	coude de jonction	x1
V	support sous tablette	x1
F	vis	x2

Sachet pour montant central n°834

Q	ferrure femelle	x5
R	ferrure mâle	x5
F	vis	x20











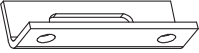
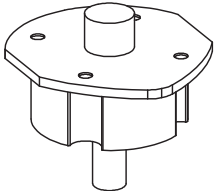

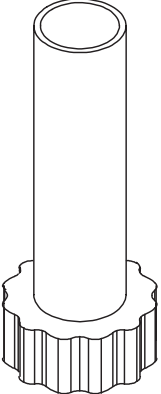

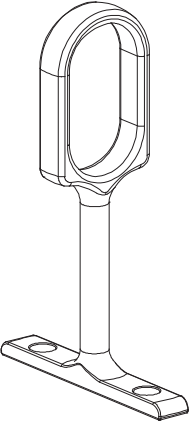

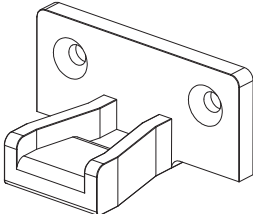

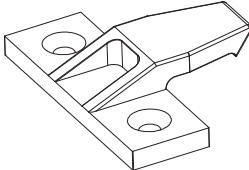
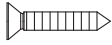
Accessoires

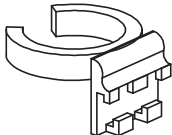
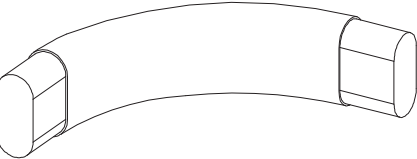
W	Convertisseur	x1
X	Rallonges	x2
Y	profil LED gauche et droit	x2

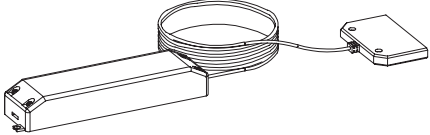
* Un sachet de caches excentrique est également fourni.

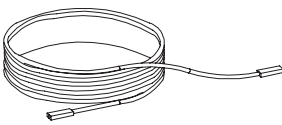
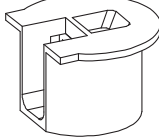
Utilisez le pour masquer les excentriques (repère K page suivante) à la fin du montage

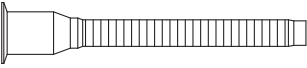
N° de sachet	825	849	801	832	846	826	827	804	847	848	828	850	834
Quantité	2	1	2	1	4	2	9	2	1	4	2	1	2

A		x2	I		x8
B		x2	J		x8
C		x12	V		x1
D		x40	Q		x10
E		x28	R		x10
F		x94	T		x10
G		x4	U		x1
H		x4	W		x1
K		x48	X		x2
L		x10	Y		x2
M		x10			
S		x18			
P		x4			

▲ Retirer les circlips sur les goujons double avant utilisation.

NUMÉROTATION DES PIÈCES : repères

2 et 16 : largeur 100 mm

21 et 22 : largeur 122 mm

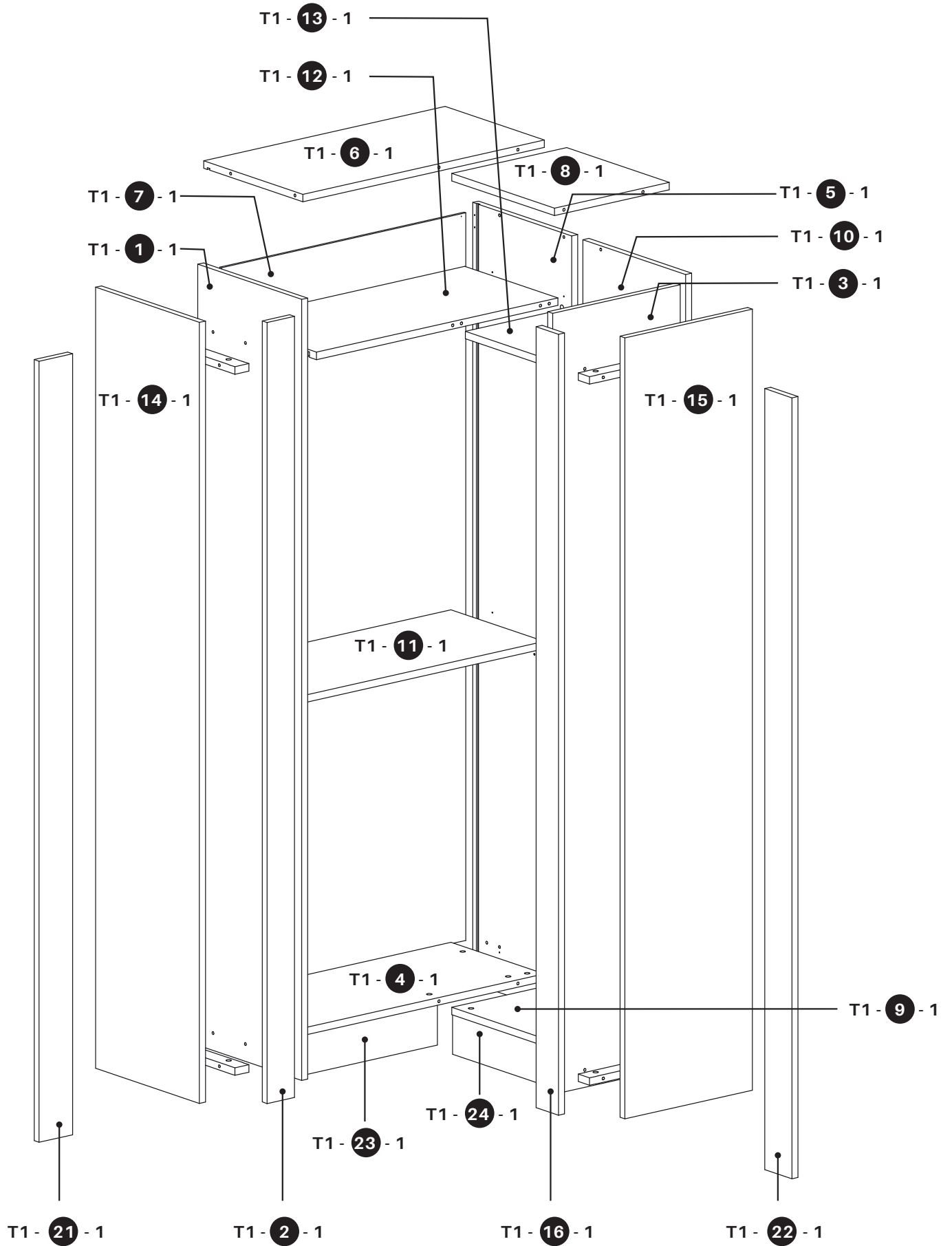

NUMÉROTATION DES PIÈCES

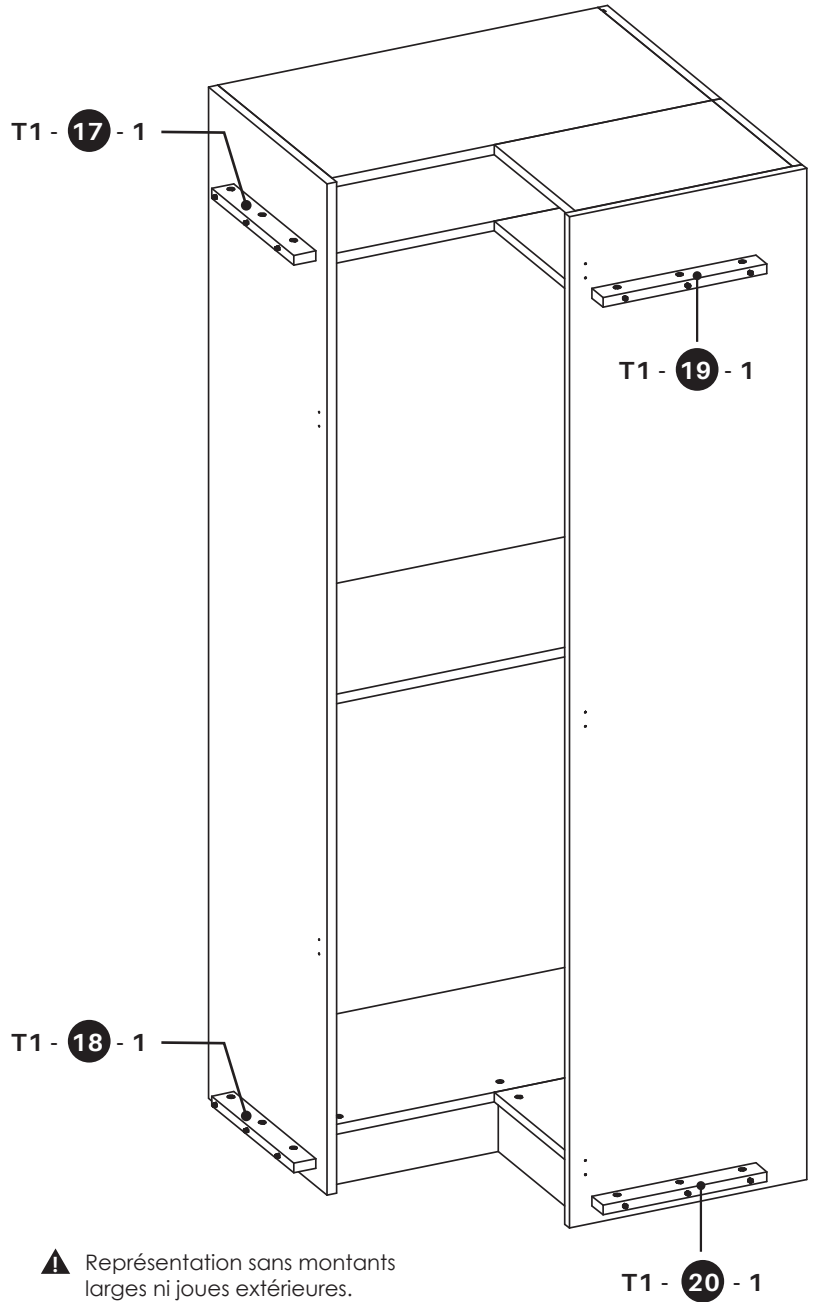
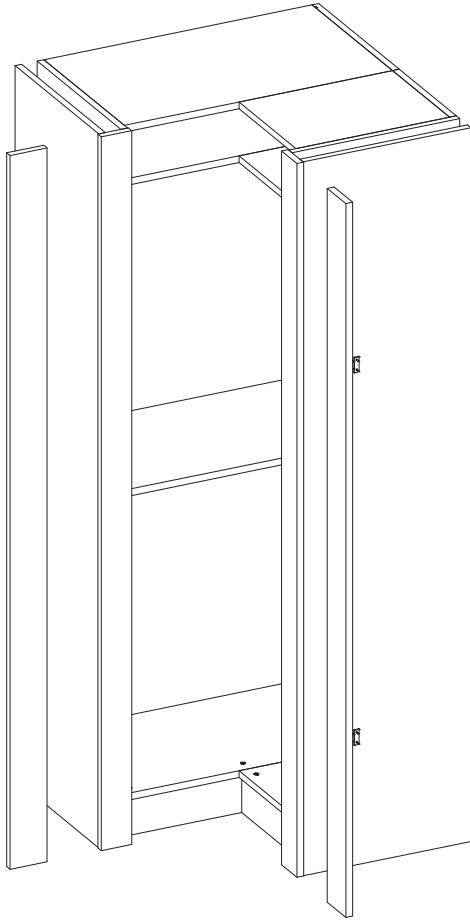

IDENTIFICATION DES PIÈCES

CCOK244603	AM006235
CPHL	
MME DUPONT	810891
SP4018164	J01 1 18/07/2022



Repère
T1-1-1
N° Module

T1 - 1 - 1

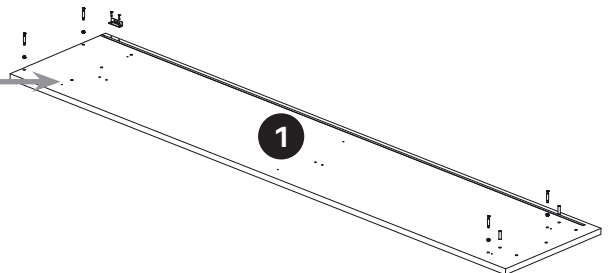

2445 x 465 x 22	OF10039732
Collection rangement Konsilio 1 espace d'angle	
Blanc Mat Colis 2 Joue Gauche	

ÉTIQUETTE PRODUIT

NUMÉROTATION NOTICE

AVANT DE COMMENCER

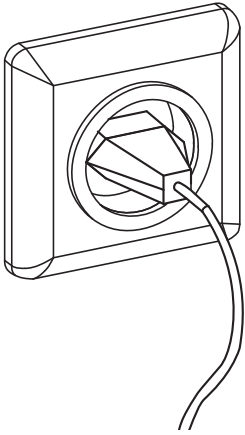

Si la prise électrique sur laquelle vous souhaitez brancher votre système LED n'est plus accessible après le montage de votre meuble, branchez la prise électrique en premier lieu.

1.

OUTILS

tournevis



maillet

QUINCAILLERIE

Sachet n°825

A	équerre	x1
C	tourillon	x2
D	insert métallique	x4
E	goujon fil métal	x4
F	vis	x2

Accessoires

Y	profil LED	x1
---	------------	----

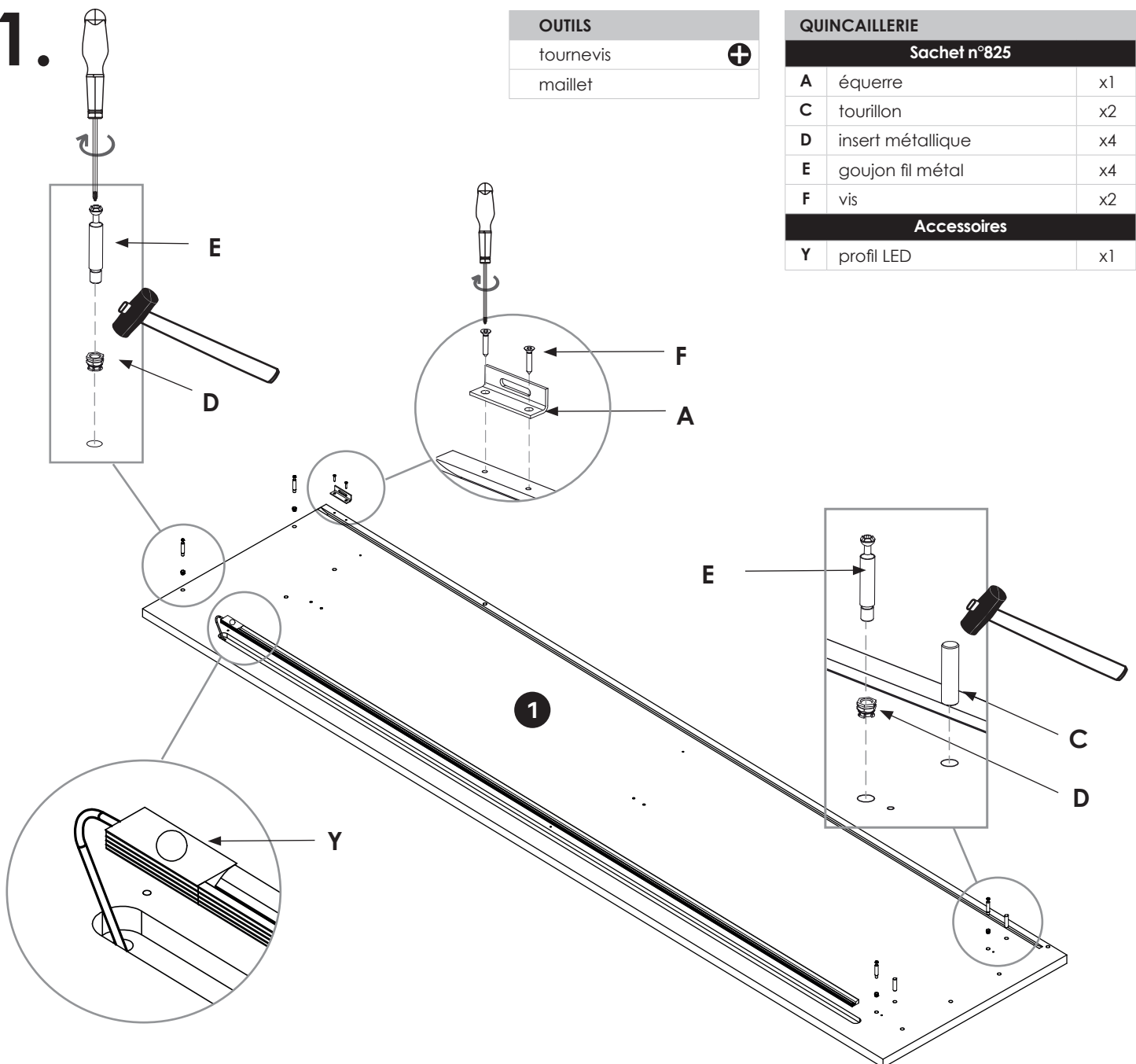

⚠ Les inserts **D** doivent être affleurants à la surface de la joue.

2.

OUTILS

tournevis



QUINCAILLERIE

Sachet n°826

I	embase	x4
F	vis	x16

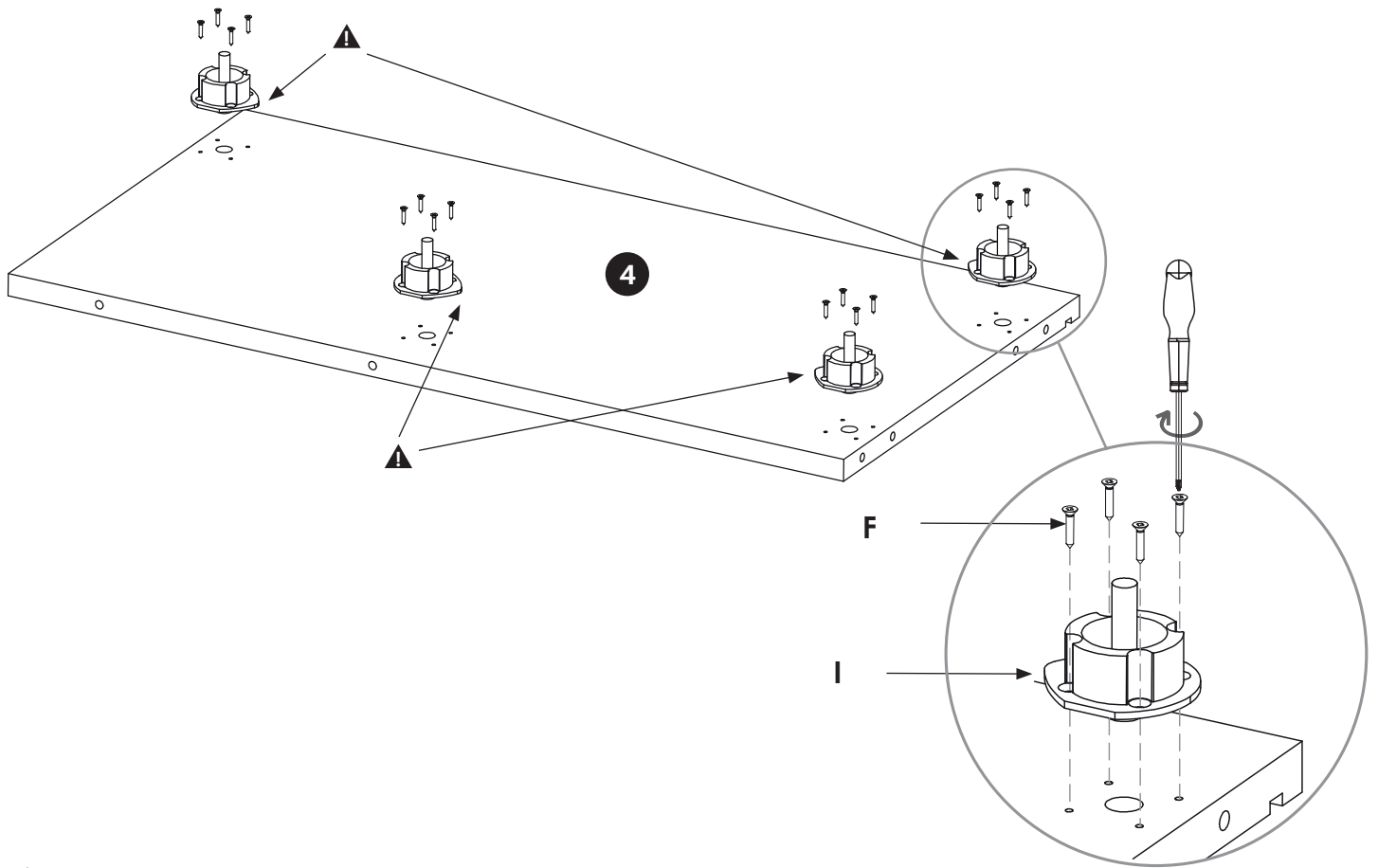

⚠ Les embases doivent être positionnées avec la pointe vers l'intérieur de la tablette.

3.

QUINCAILLERIE

Sachet n°826

J	piéd	x4
---	------	----

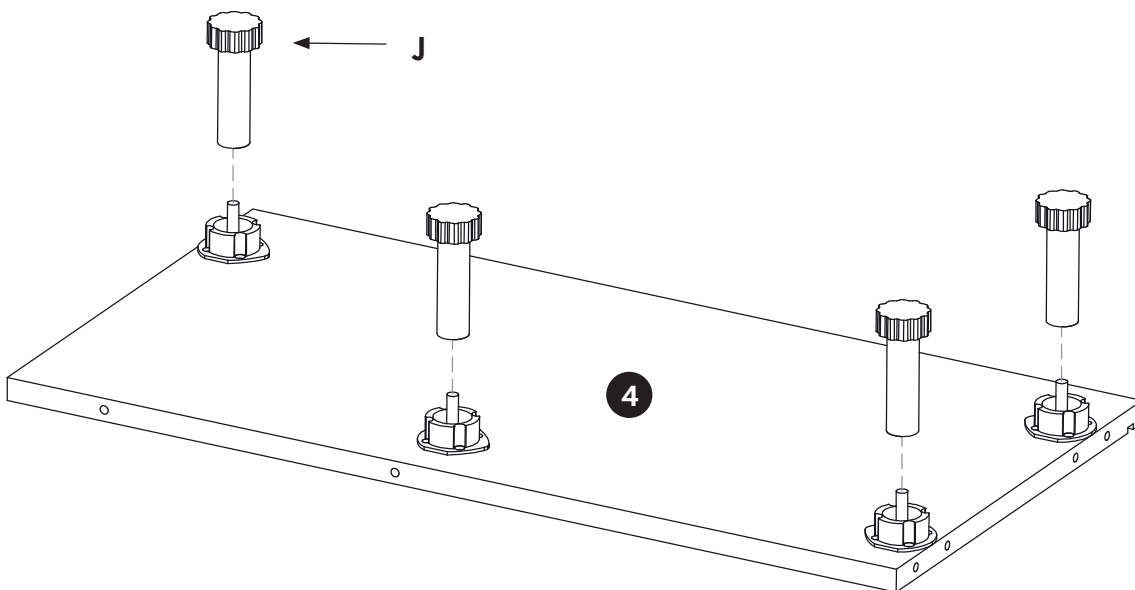

4.

Ajuster la longueur des pieds de réglage pour que la tablette ④ se trouve à 123 mm du sol, cette position pouvant varier selon la planéité du sol.

QUINCAILLERIE

	Sachet n°827	x1 1/2
K	excentrique	x6

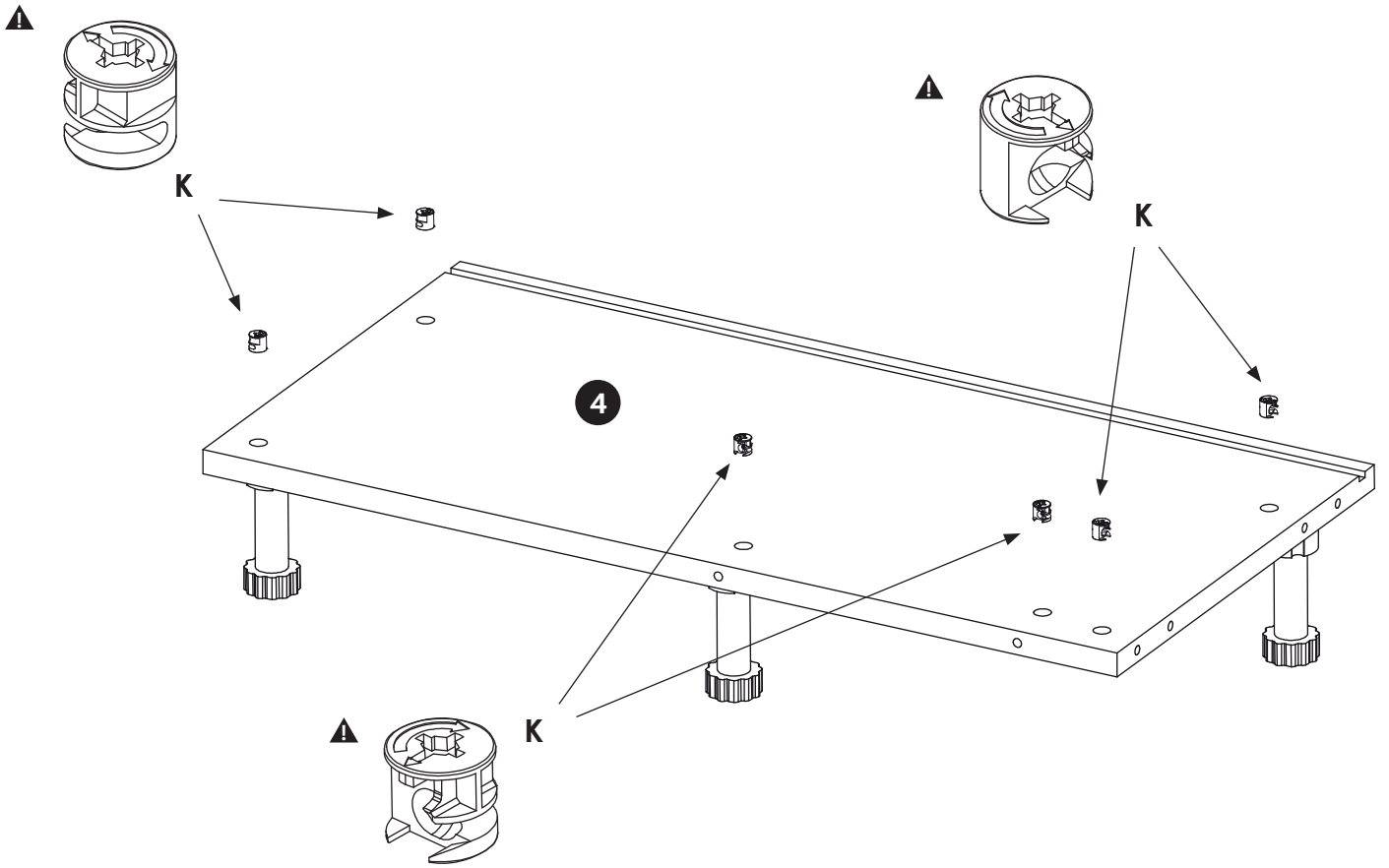

⚠ La flèche des excentriques est orientée vers l'extérieur de la tablette.

5.

QUINCAILLERIE

	Sachet n°827	x1 1/2
K	excentrique	x6

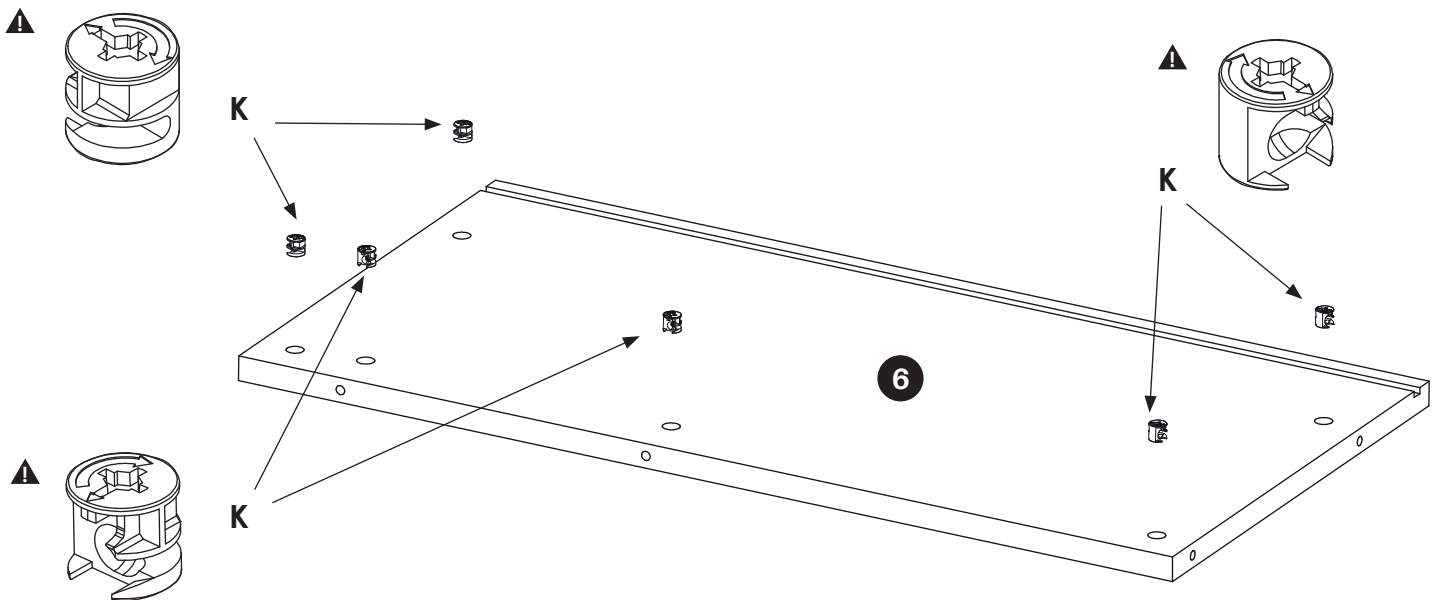



⚠ La flèche des excentriques est orientée vers l'extérieur de la tablette.

6.

OUTILS

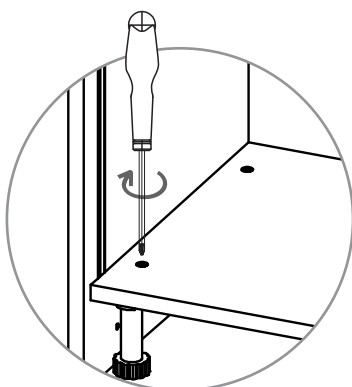
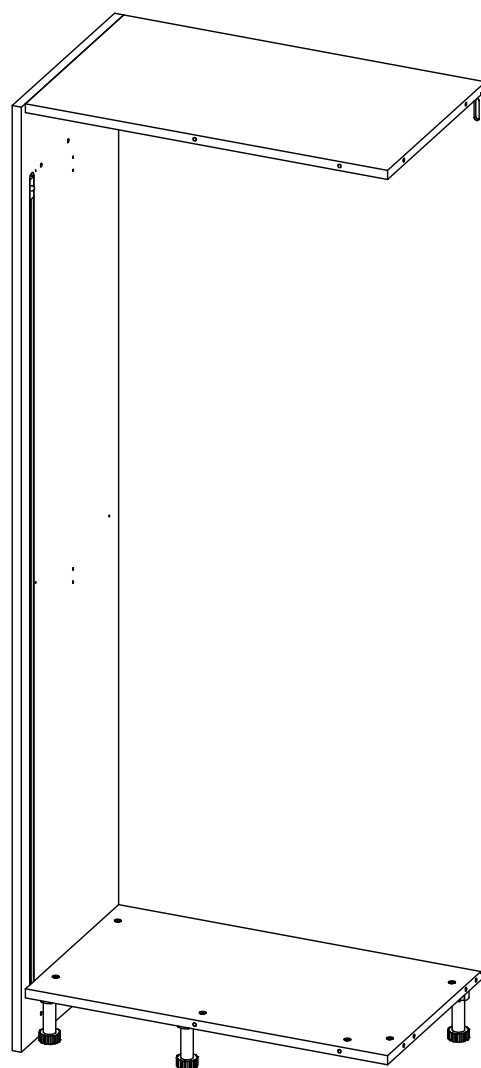
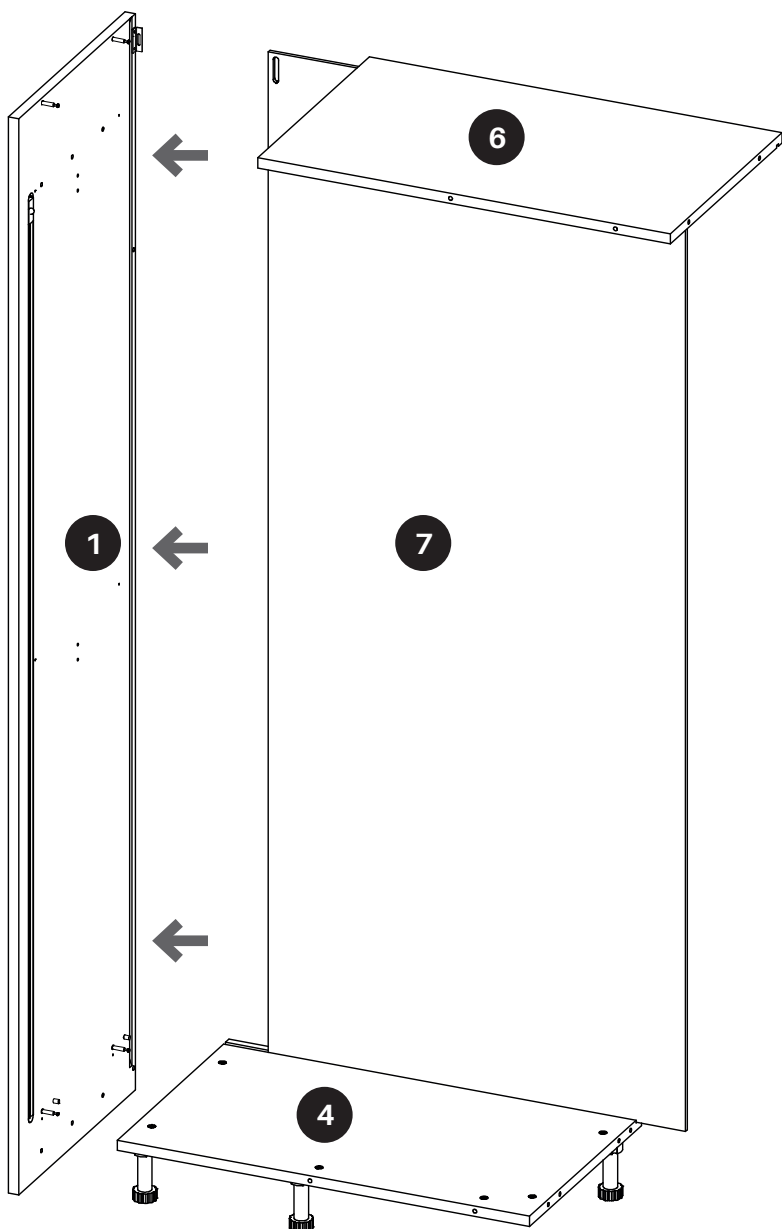
tournevis



 Serrer les excentriques dans le sens horaire

7.

OUTILS

tournevis	+
maillet	

QUINCAILLERIE

Sachet n°825		
A	équerre	x1
C	tourillon	x2
D	insert métallique	x4
E	goujon fil métal	x4
F	vis	x2
Sachet n°827		
K	excentrique	x4

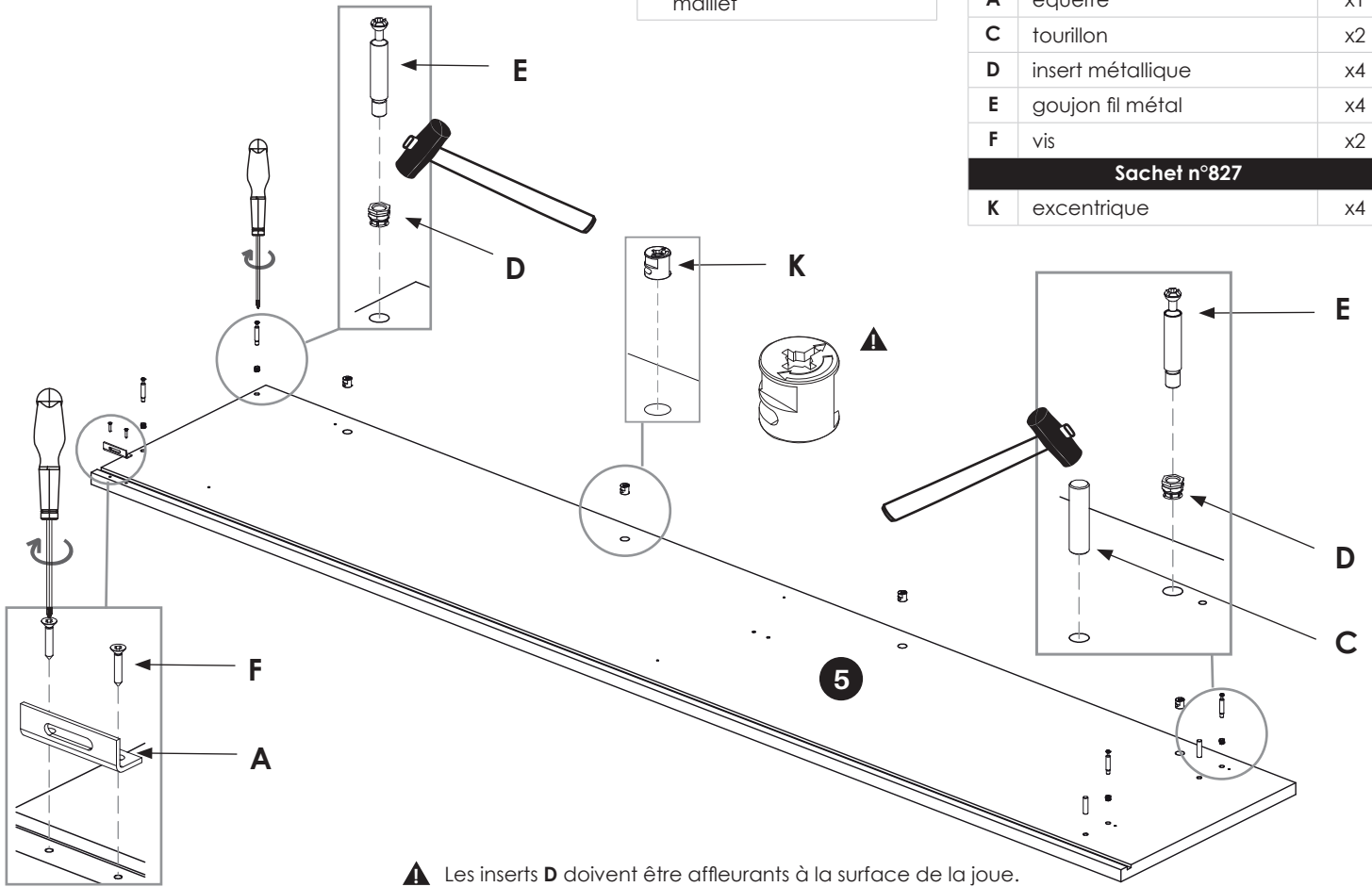

8.

OUTILS

tournevis	+
-----------	---

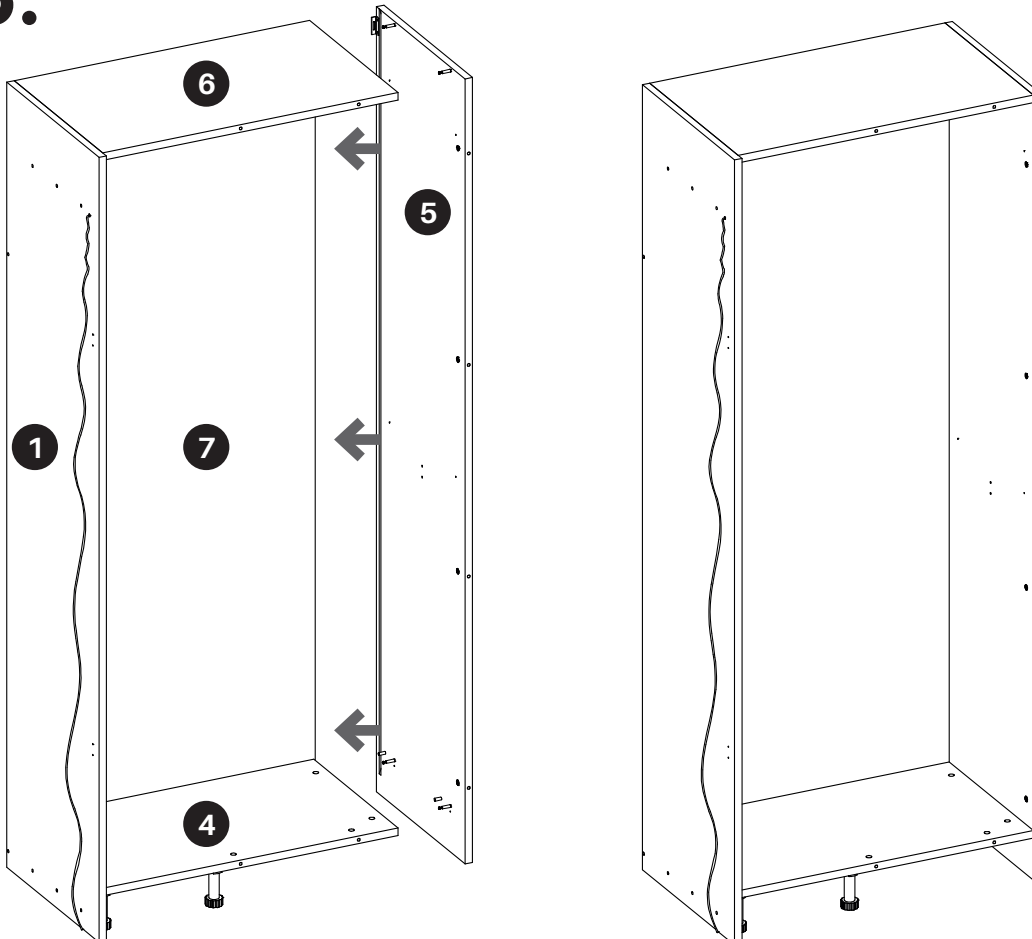

▲ Serrer les excentriques dans le sens horaire

9.

OUTILS

tournevis

QUINCAILLERIE

Sachet n°834

R	ferrure mâle	x2
F	vis	x4

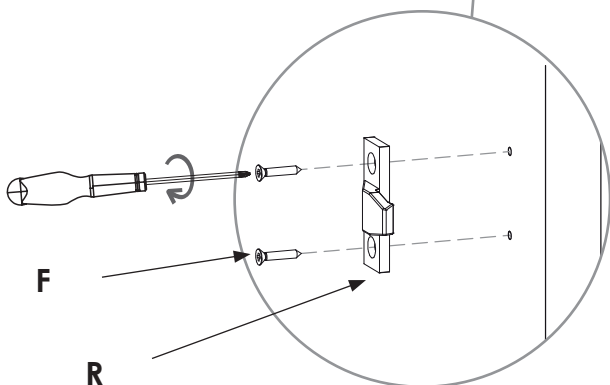

10.

Présentation sans tablette haute.

OUTILS

crayon
perceuse

QUINCAILLERIE

FIXATION MURALE :
VIS ET CHEVILLES NON FOURNIES

⚠ Utiliser des vis, rondelles et chevilles adaptées à votre mur.

ÉTAPE 1

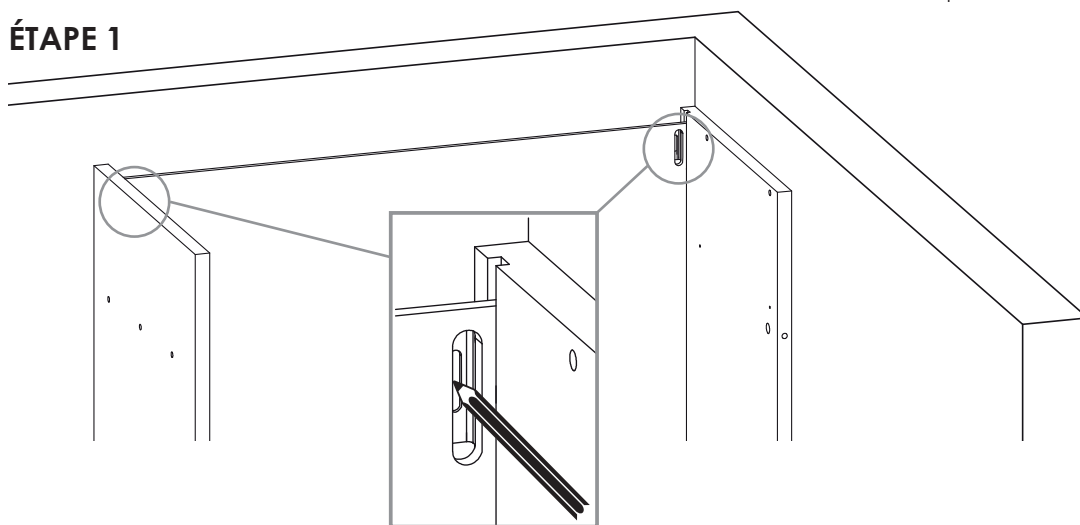

ÉTAPE 2

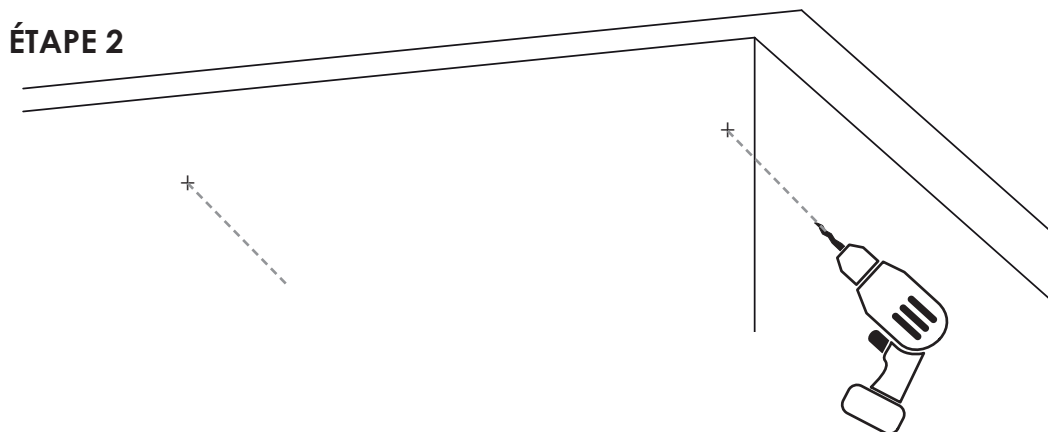

11.

Présentation sans tablette haute.

OUTILS

visseuse

QUINCAILLERIE

FIXATION MURALE :
VIS ET CHEVILLES NON FOURNIES

⚠ Utiliser des vis, rondelles et chevilles adaptées à votre mur.

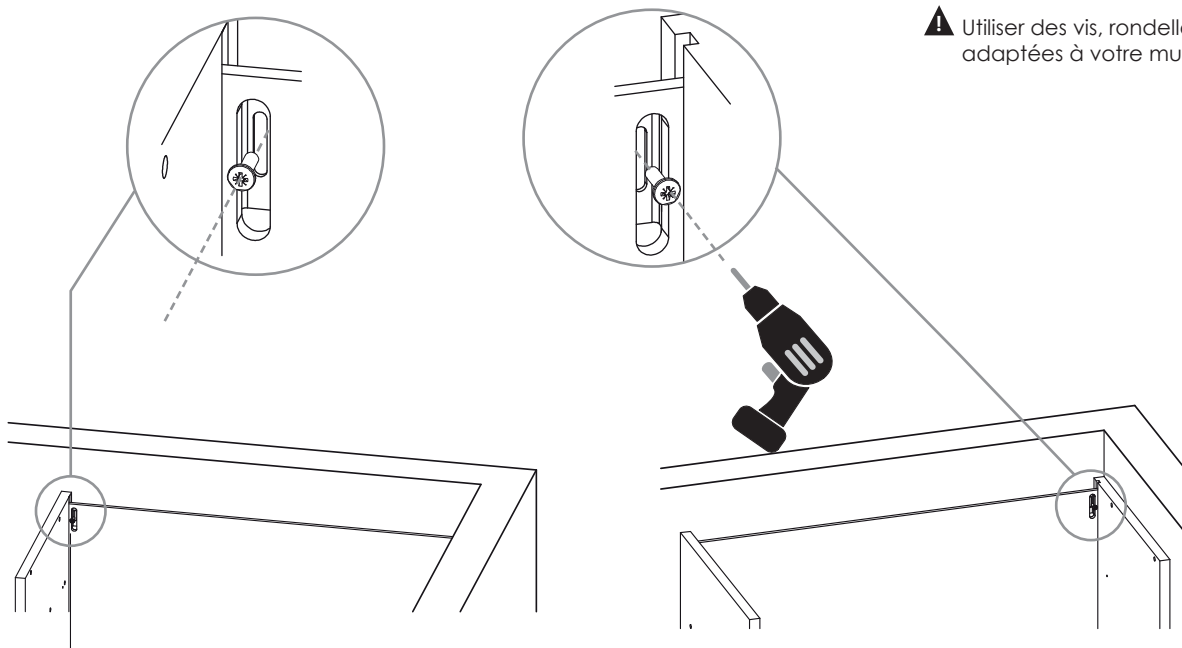

12.

x4

17, 18, 19 et 20

OUTILS

tournevis

QUINCAILLERIE

Sachet n°846		x4
K	excentrique	x12

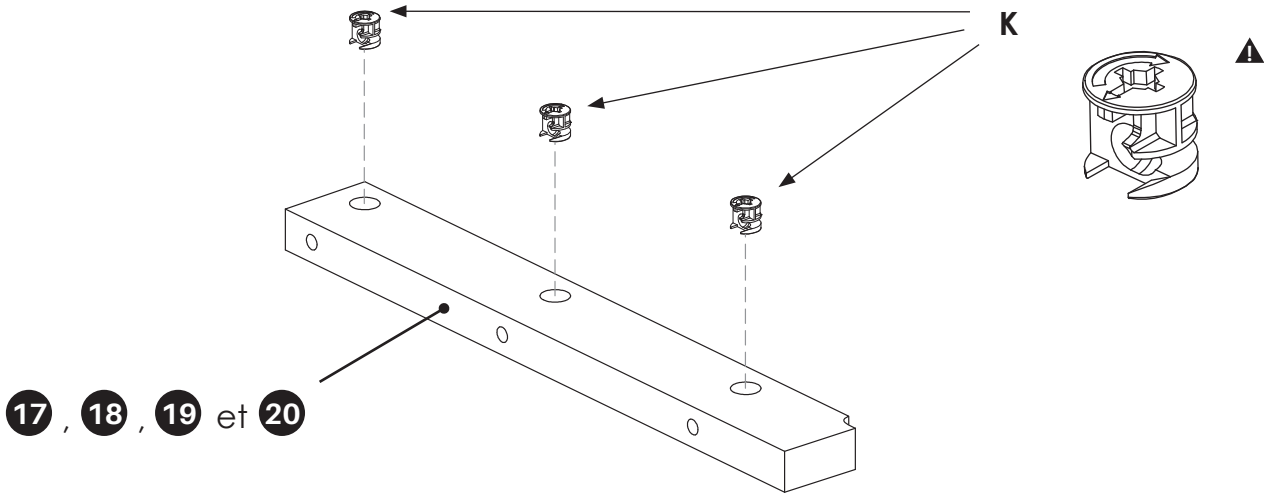

⚠ À l'orientation de la flèche des excentriques.

13.

OUTILS

tournevis



maillet

QUINCAILLERIE

Sachet n°846		x2
D	insert métallique	x6
E	goujon fil métal	x6
Sachet n°834		
R	ferrure femelle	x3
F	vis	x6

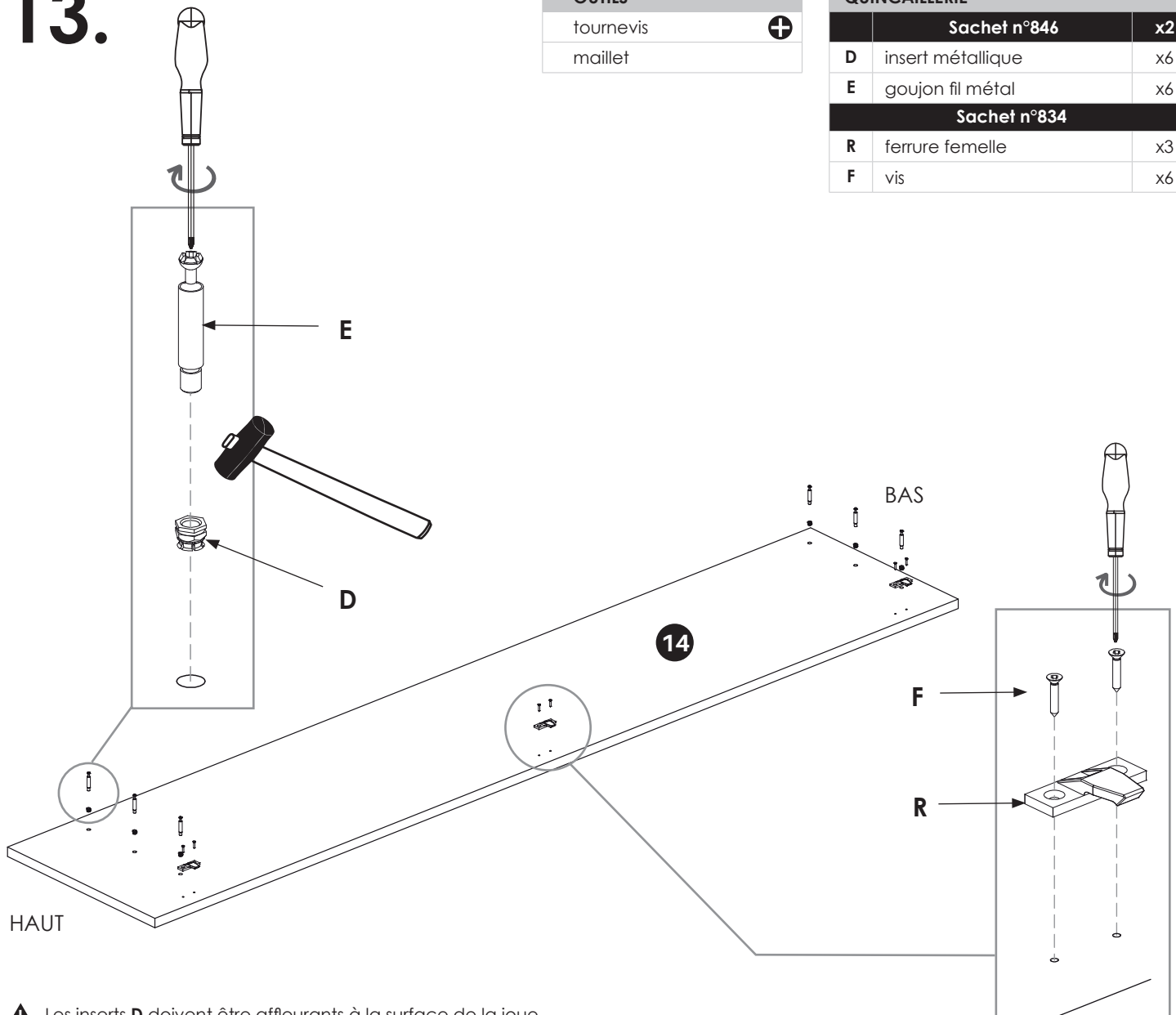

⚠ Les inserts D doivent être affleurants à la surface de la joue.

14.

OUTILS

tournevis



ÉTAPE 1

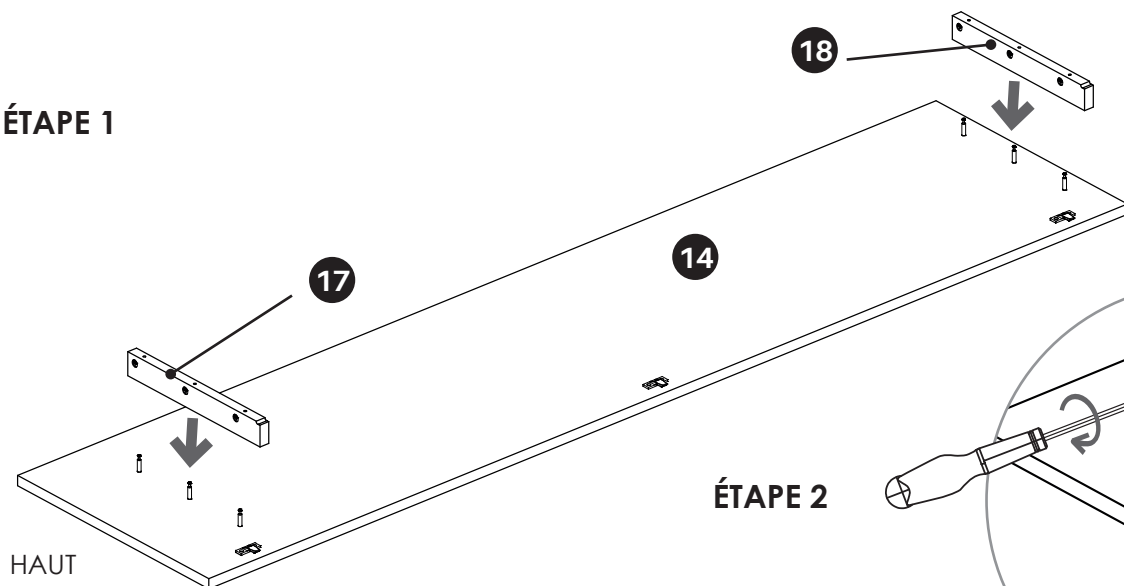

ÉTAPE 2

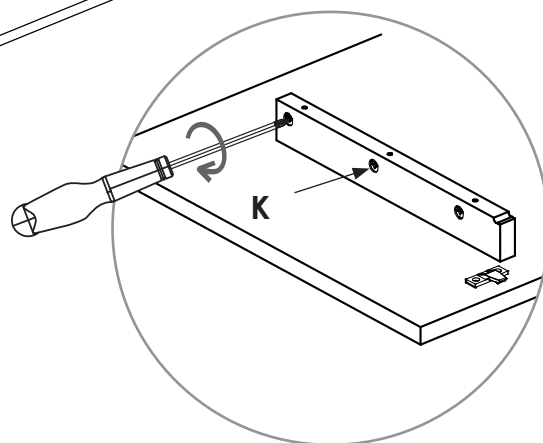

15.

OUTILS

clé 6 pans

QUINCAILLERIE

Sachet n°846		x2
S	vis	x6

⚠ Faire passer le câble de profil LED dans le trou traversant l'épaisseur du tasseau vers le bas ou vers le haut pour éviter de le pincer. Le raccorder au convertisseur W.

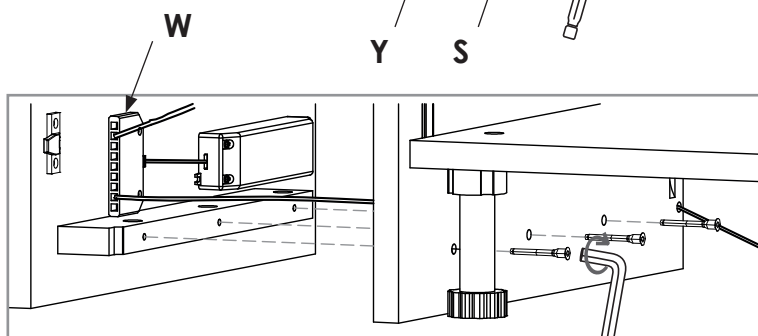
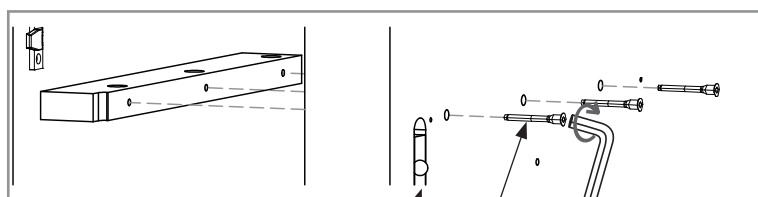
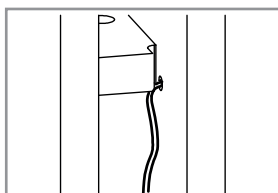

Note : Le pied de réglage arrière n'est pas représenté.

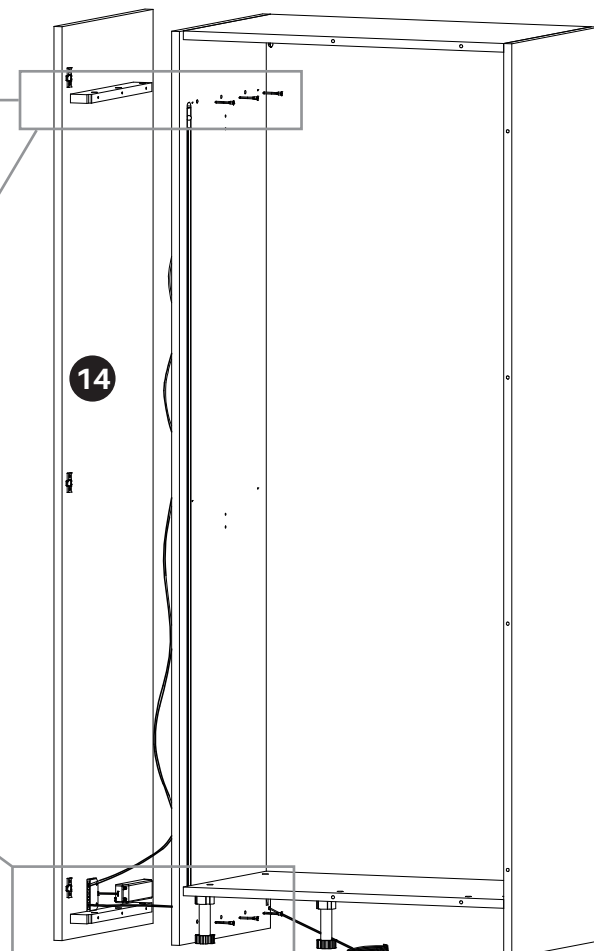

⚠ Faire passer une rallonge X sous la tablette basse, en passant par le trou situé à l'arrière de la joue, afin de la raccorder au convertisseur W.

X

16.

OUTILS

maillet

QUINCAILLERIE

Sachet n°804

L	boitier	x4
Sachet n°827		1/2
K	excentrique	x2

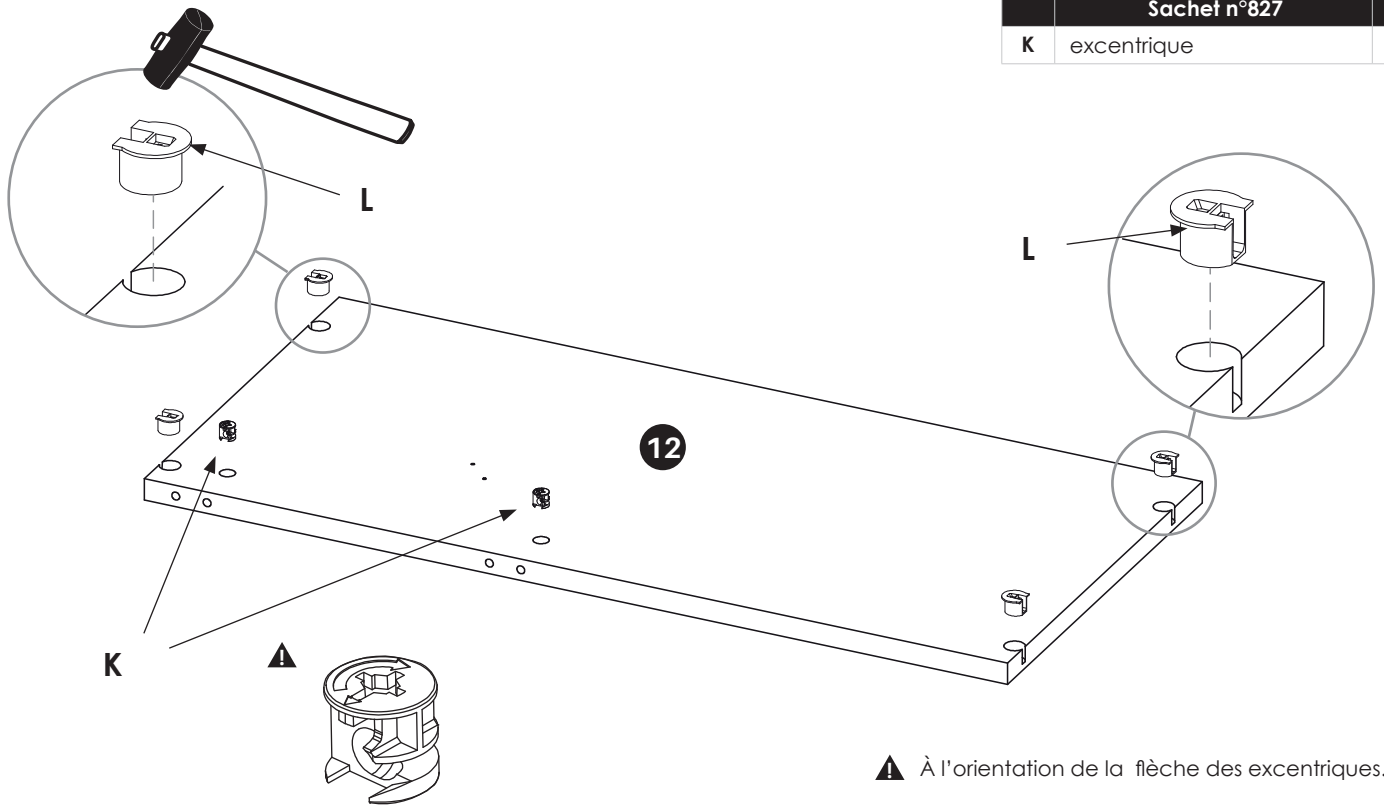

17.

OUTILS

tournevis



QUINCAILLERIE

Sachet n°804

M	goujon	x4
---	--------	----

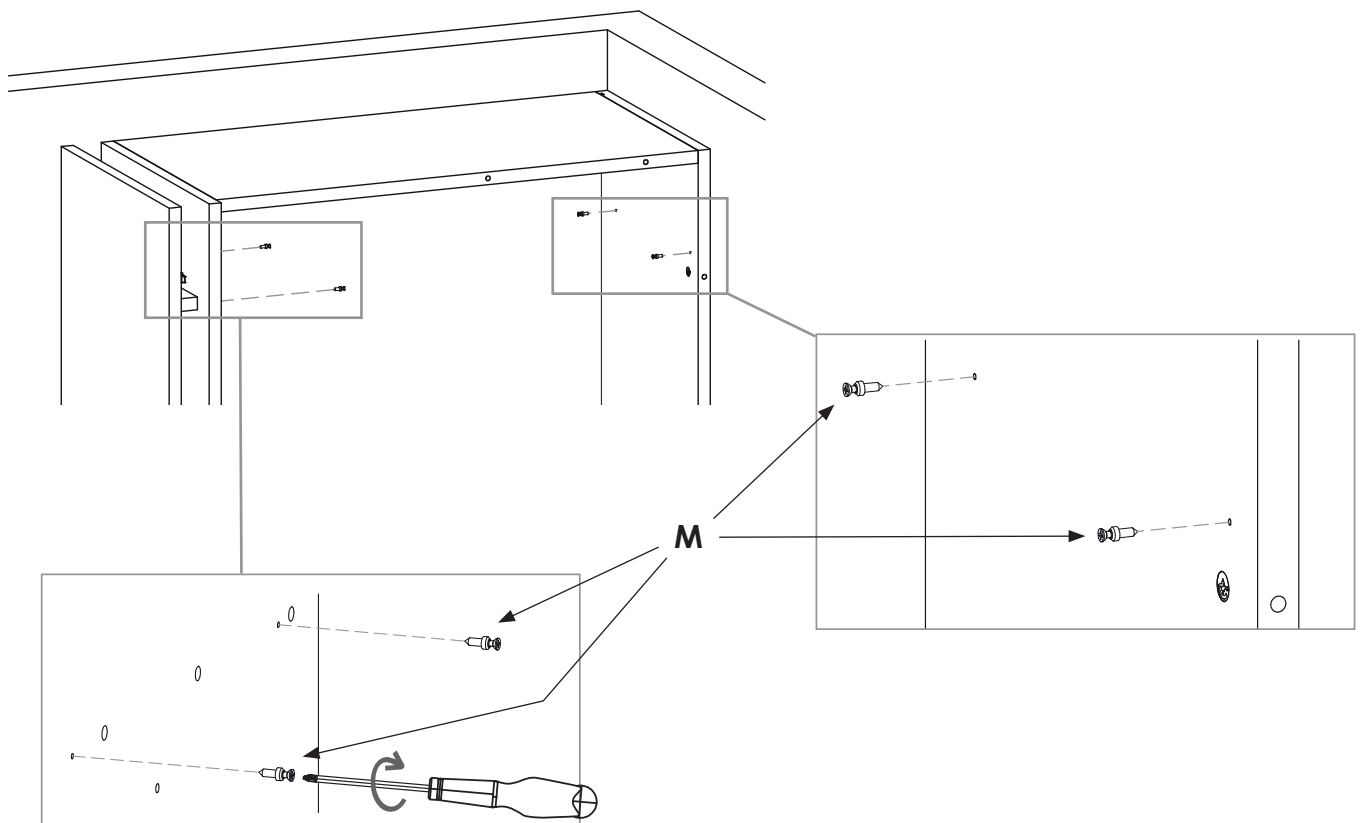

18.

OUTILS

tournevis



ÉTAPE 1

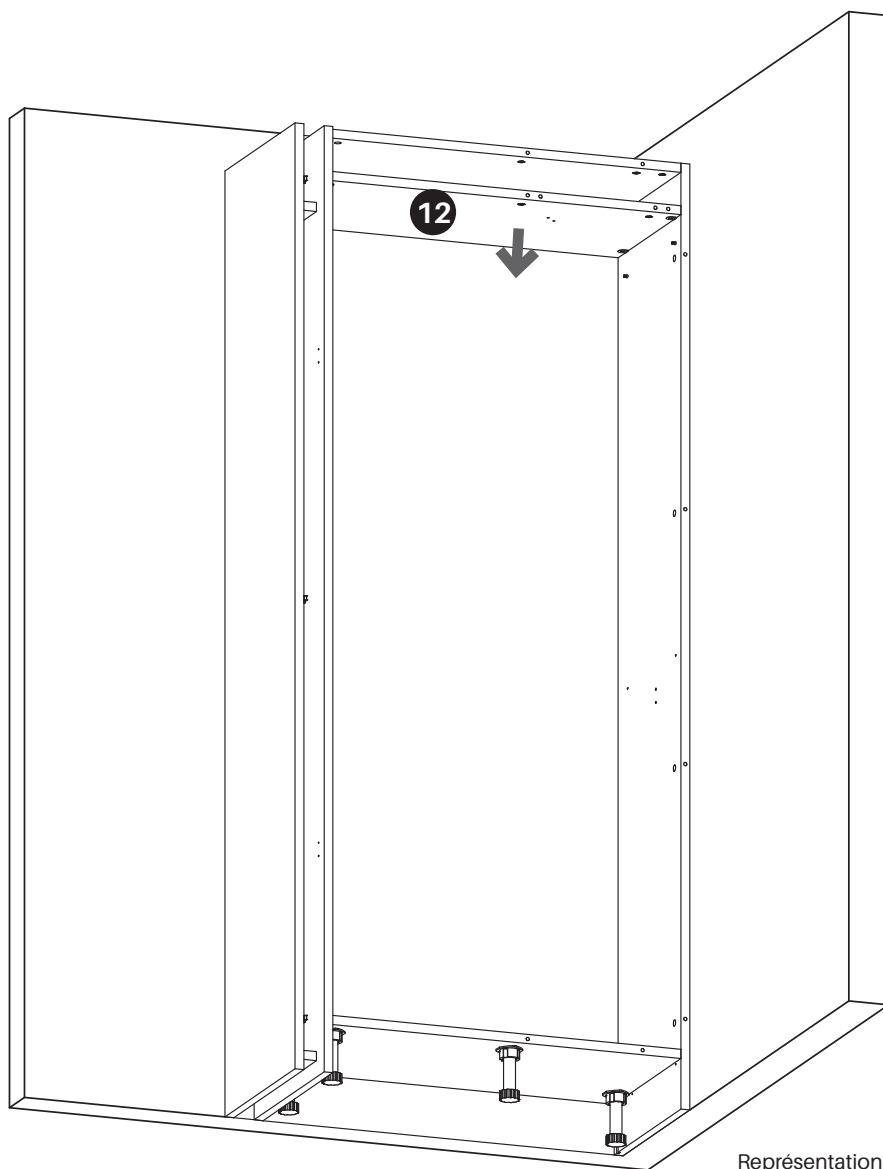

Représentation sans rallonge X

ÉTAPE 2

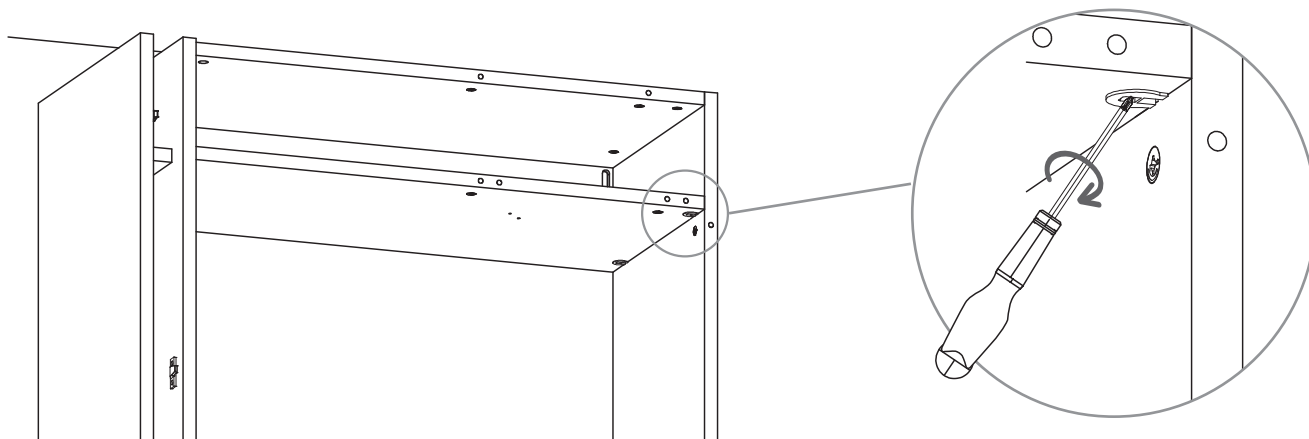

19.

OUTILS

tournevis



QUINCAILLERIE

Sachet n°847

C	tourillon	x2
---	-----------	----

T	goujon double	x2
---	---------------	----

Sachet n°848

T	goujon double	x8
---	---------------	----

⚠ Pensez à retirer les circlips sur les goujons double avant utilisation.

Le goujon double peut être inséré dans n'importe quel sens.

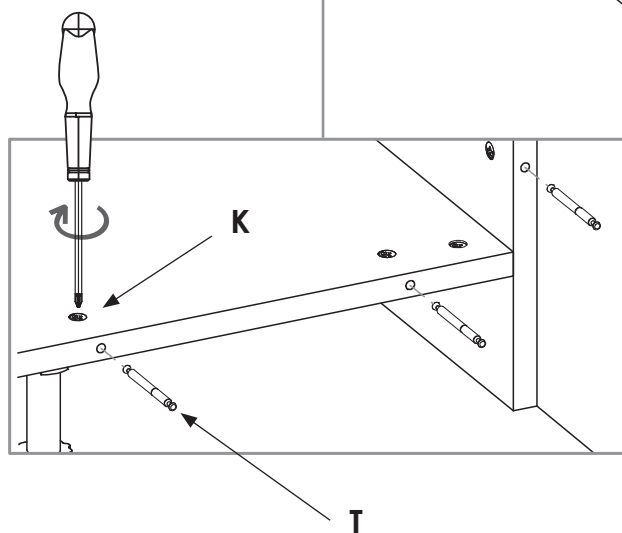
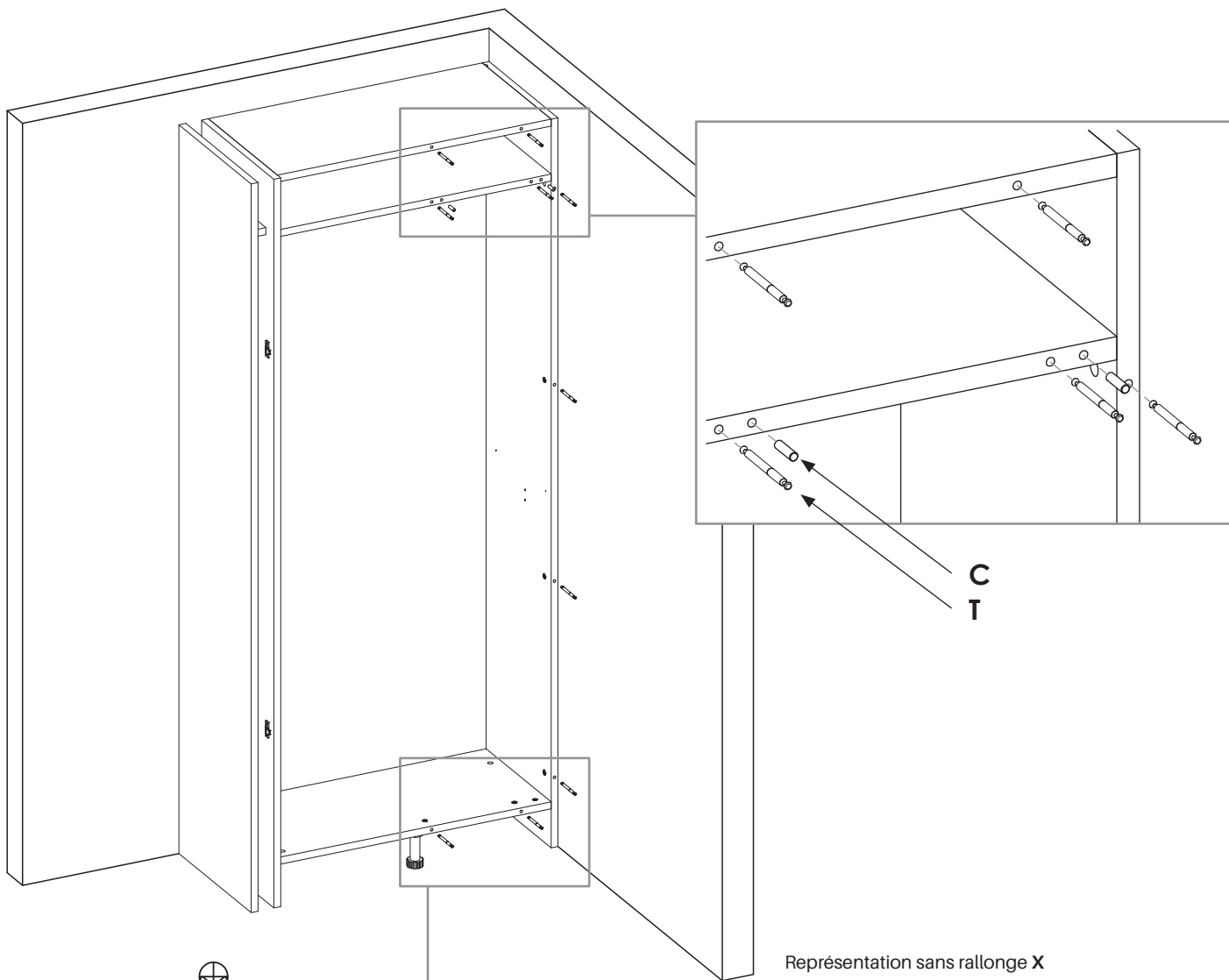
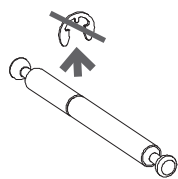

20.

QUINCAILLERIE

Sachet n°827		
K	excentrique	x8

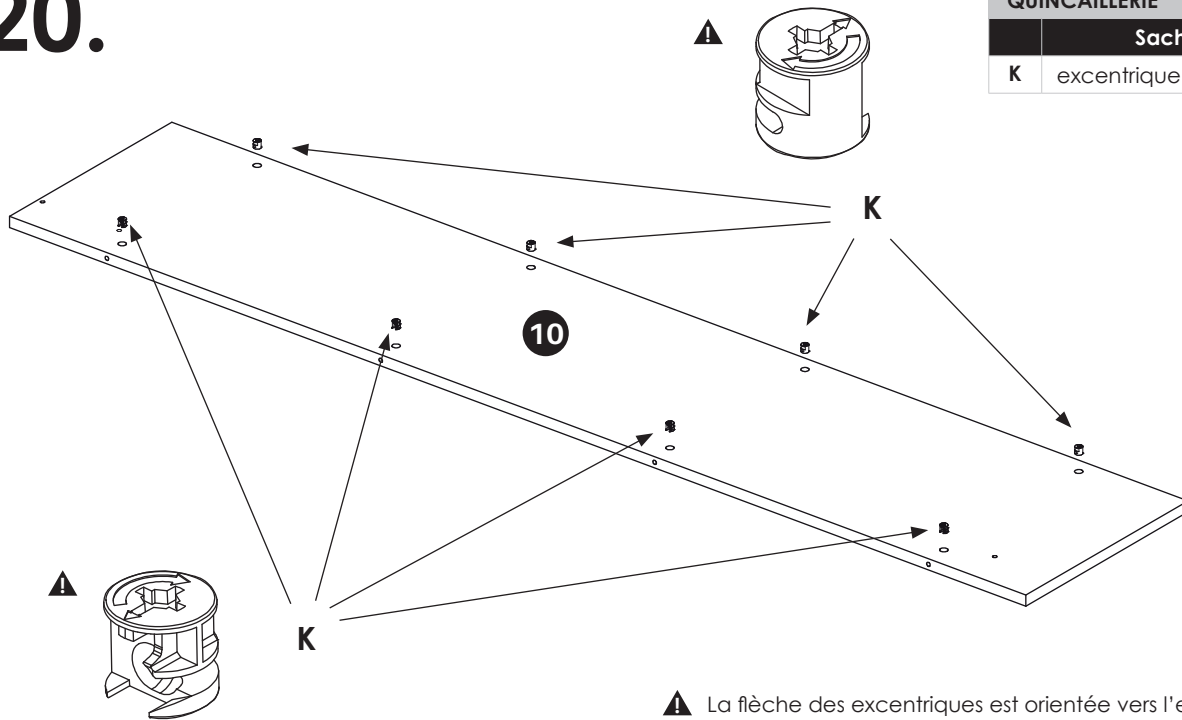

⚠ La flèche des excentriques est orientée vers l'extérieur de la joue.

21a.

OUTILS

tournevis	+
maillet	

QUINCAILLERIE

Sachet n°849		
D	insert métallique	x8
E	goujon fil métal	x8
C	tourillon	x6
Sachet n°827		
K	excentrique	x4
Accessoires		
Y	profil LED	x1

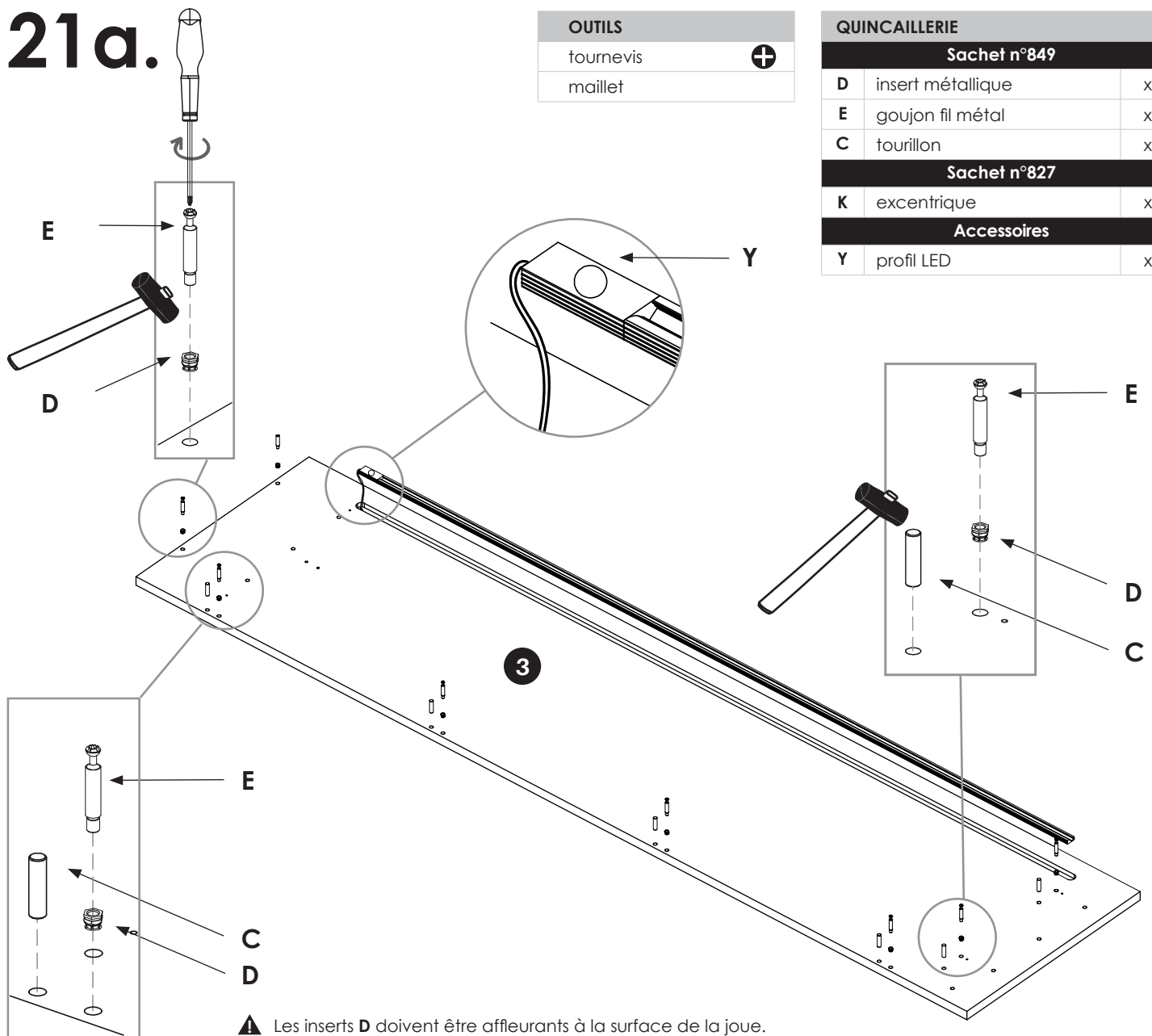

⚠ Les inserts **D** doivent être affleurants à la surface de la joue.

21b.

OUTILS

tournevis 

QUINCAILLERIE

Sachet n°834

R	ferrure mâle	x3
F	vis	x6

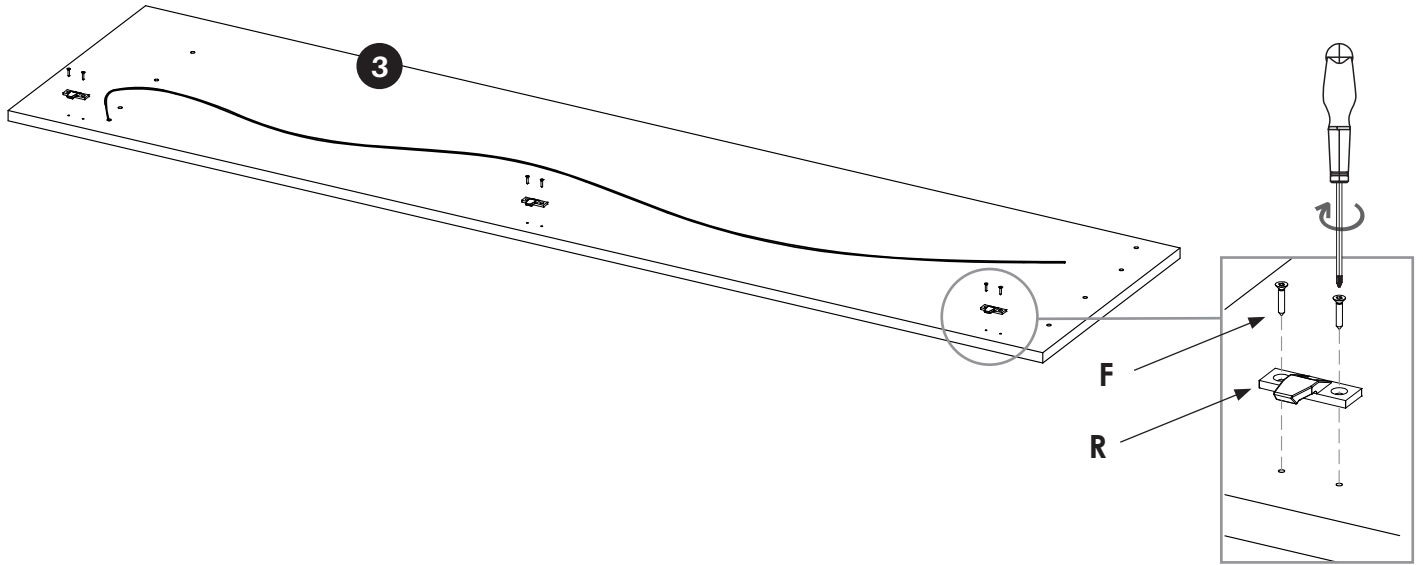

22.

OUTILS

tournevis 

ÉTAPE 1

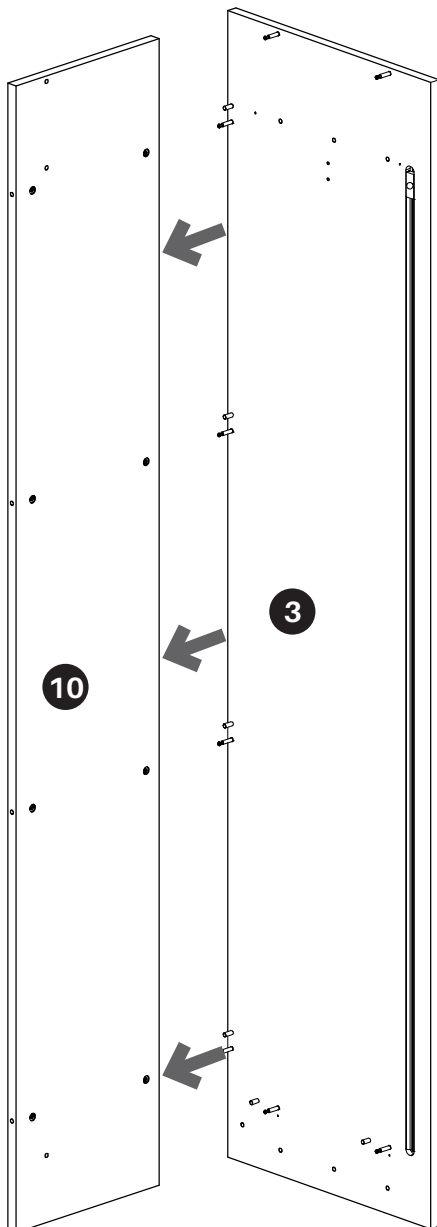

ÉTAPE 2

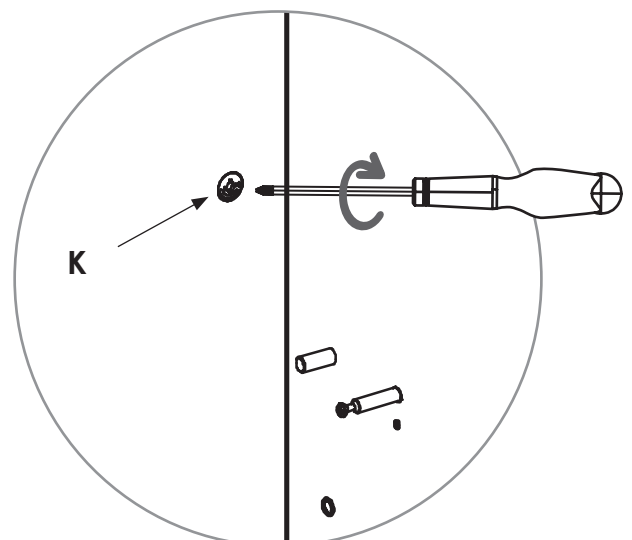

23.

OUTILS

tournevis	+
maillet	

QUINCAILLERIE

Sachet n°846		
D	insert métallique	x6
E	goujon fil métal	x6
Sachet n°834		
R	ferrure mâle	x2
F	vis	x4

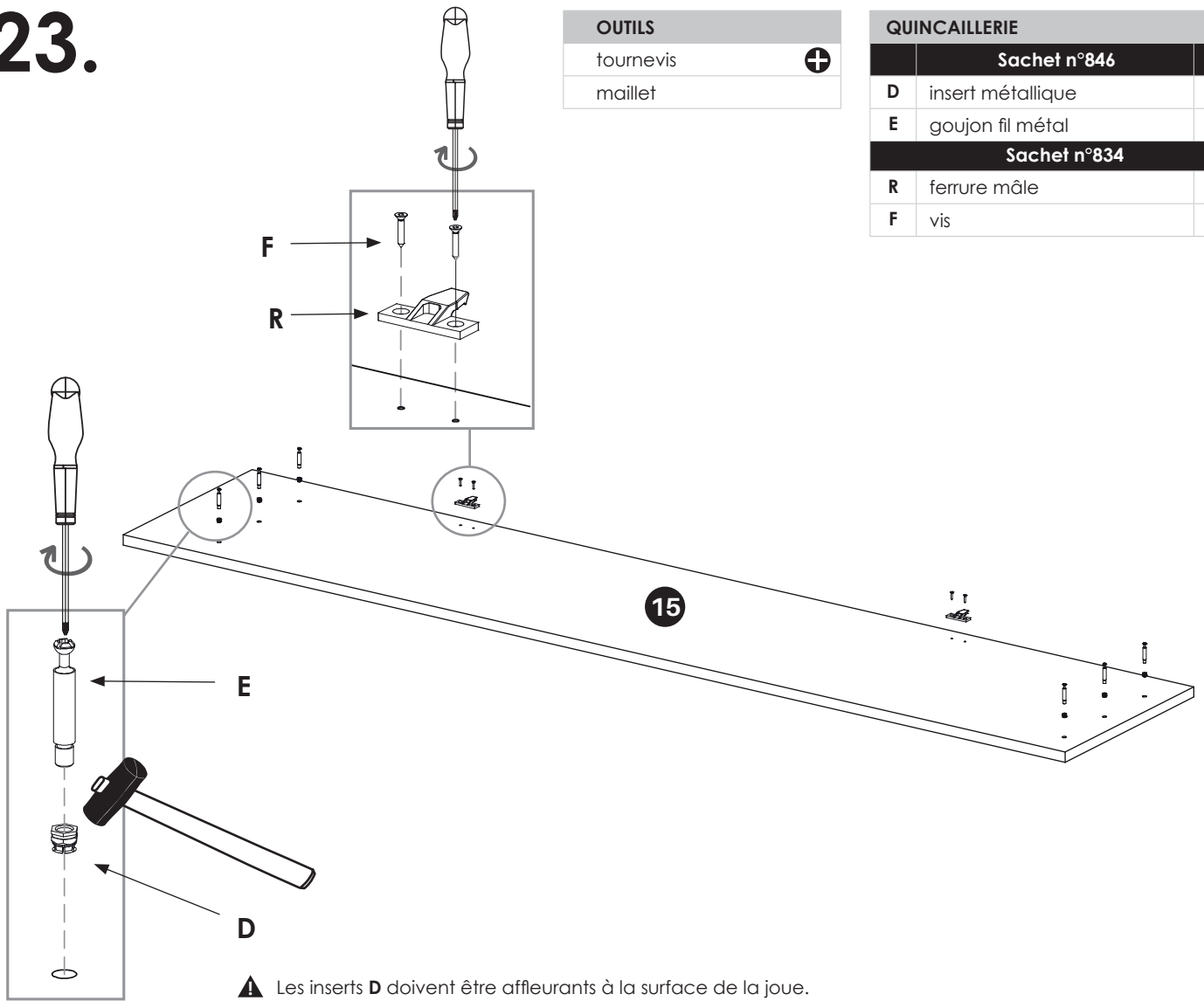

24.

OUTILS

tournevis	+
-----------	---

ÉTAPE 1

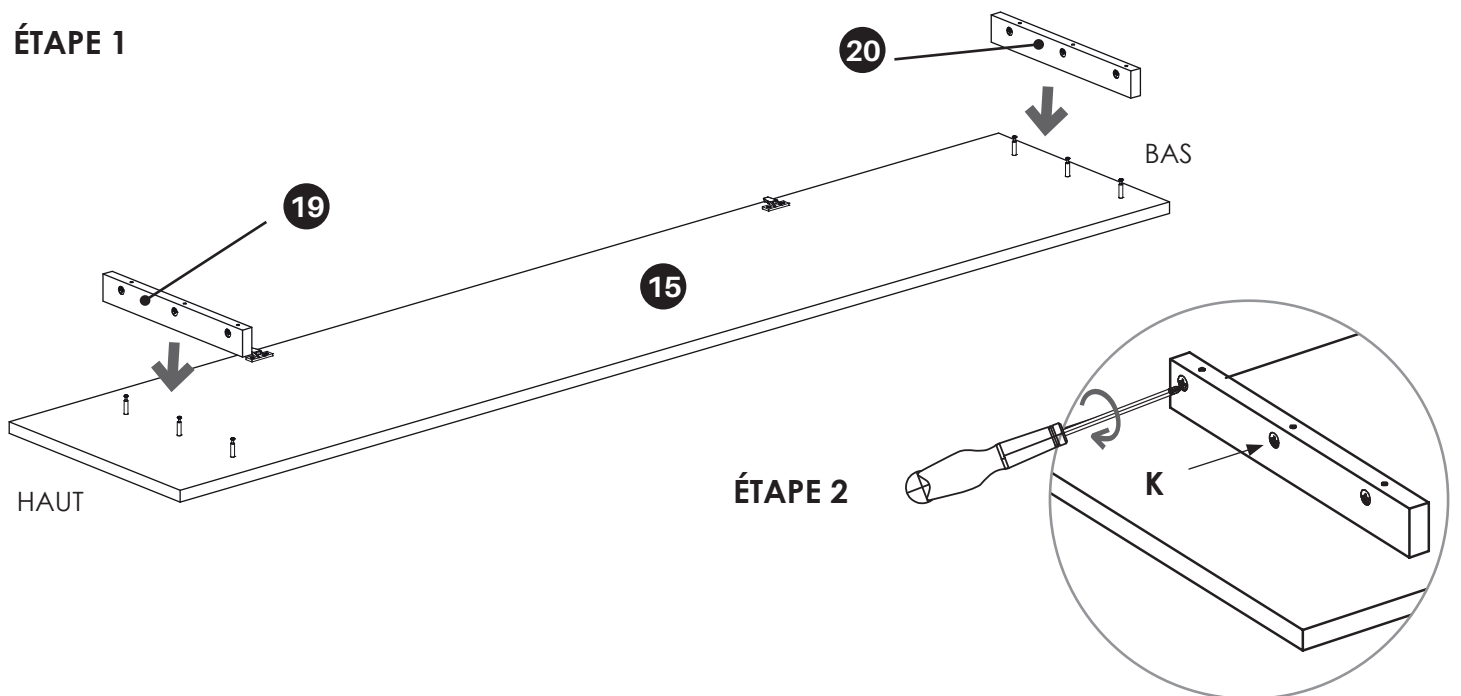

25.

OUTILS

clé 6 pans

tournevis



QUINCAILLERIE

Sachet n°846

S vis x6

Sachet n°847

M goujon x2

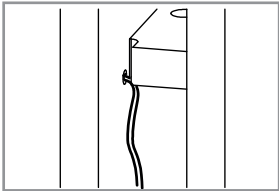

⚠ Faire passer le câble du profil LED par le trou prévu à cet effet en partie basse (voir vue ci-contre). Attention de ne pas pincer ce câble au moment de l'assemblage du panneau 15. Raccorder le câble à la rallonge X.

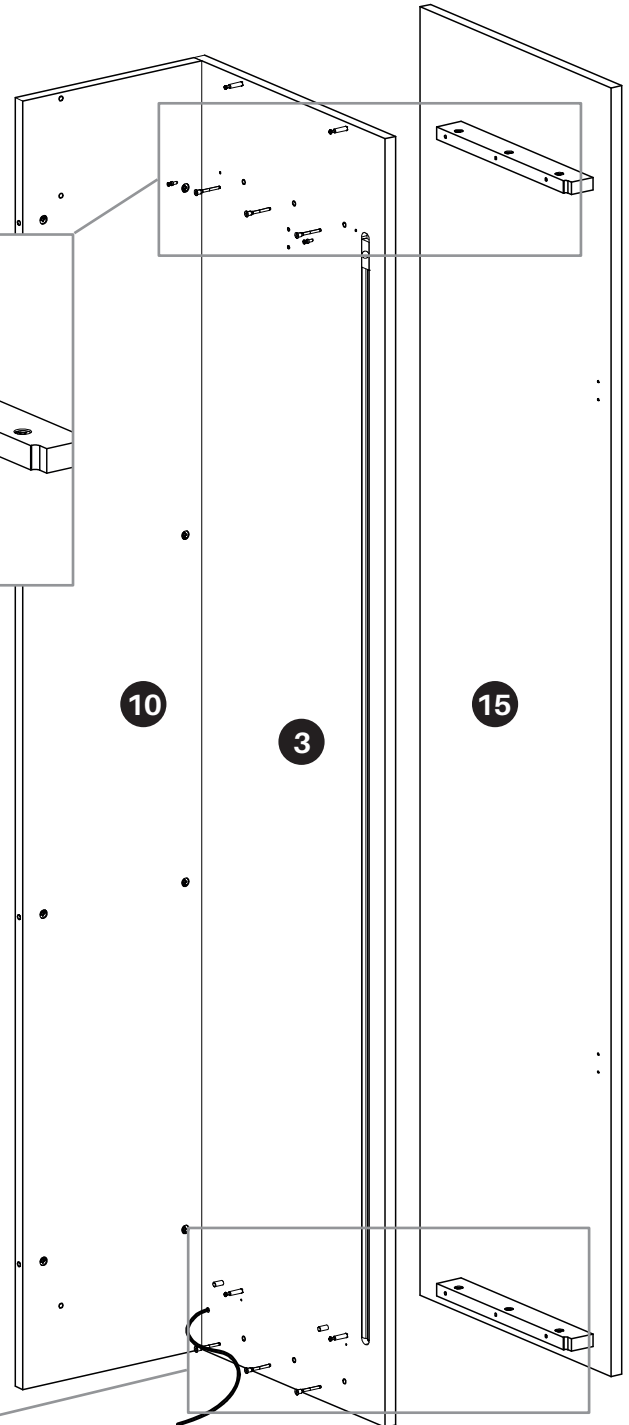
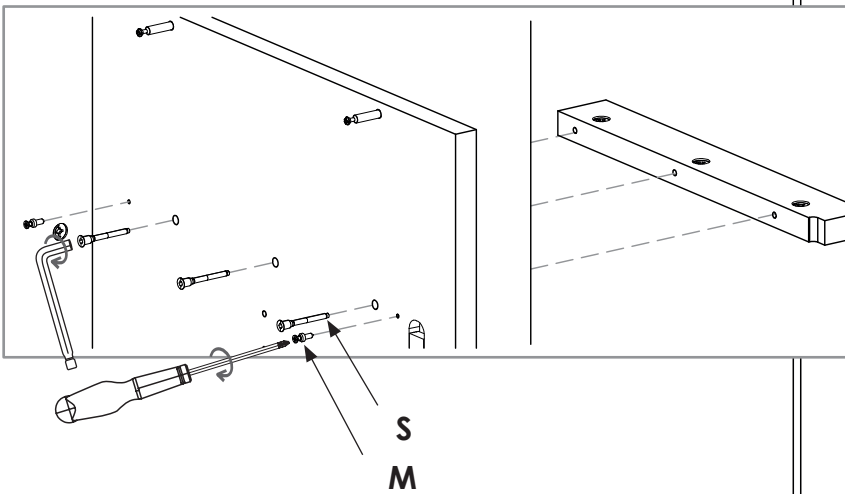

Trou de sortie pour le câble du profil LED

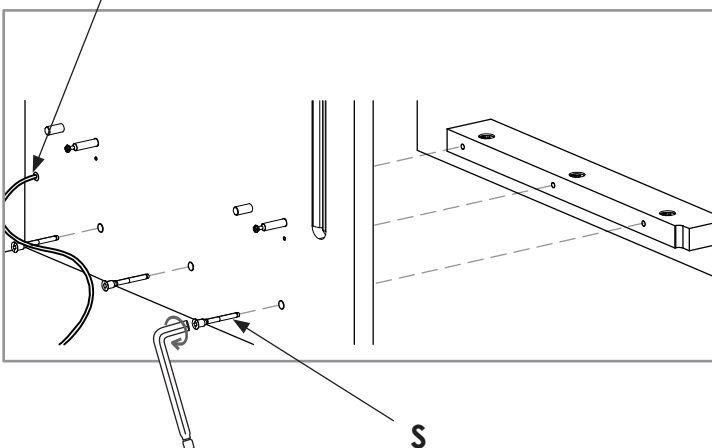

26.

QUINCAILLERIE

Sachet n°827

K	excentrique	x4
---	-------------	----

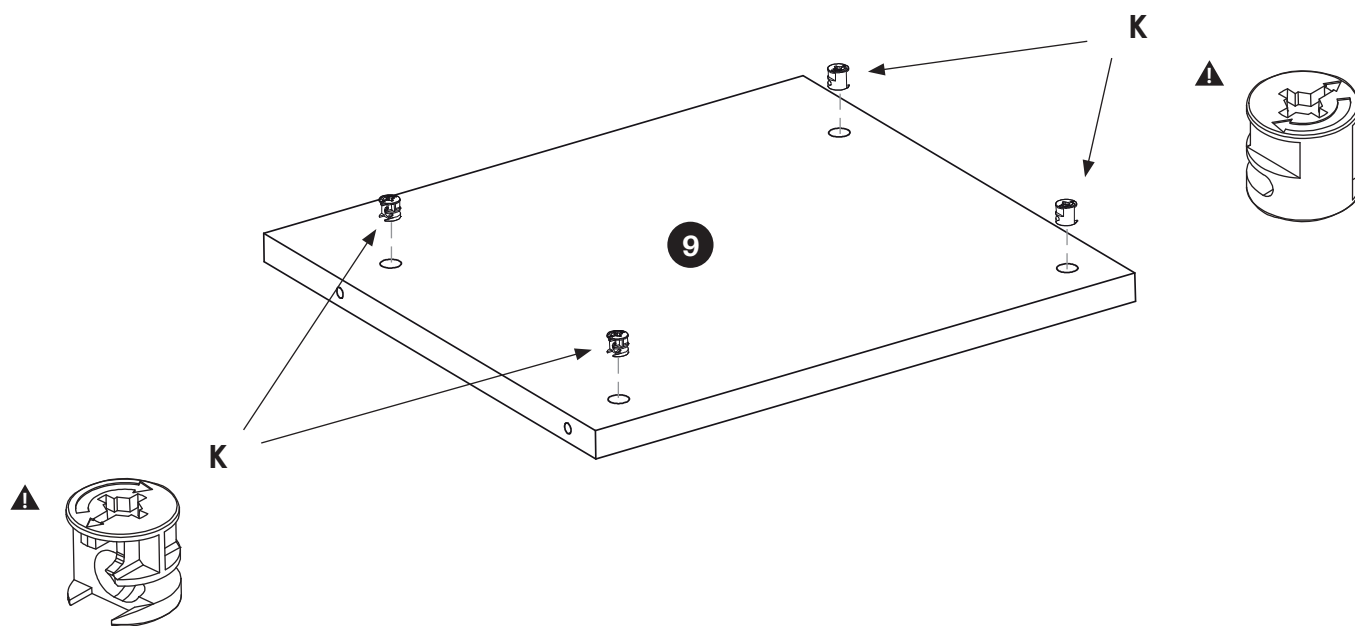

⚠ La flèche des excentriques est orientée vers l'extérieur de la tablette.

27. ↻

OUTILS

tournevis



QUINCAILLERIE

Sachet n°826

I	embase	x4
J	piéd	x4
F	vis	x16

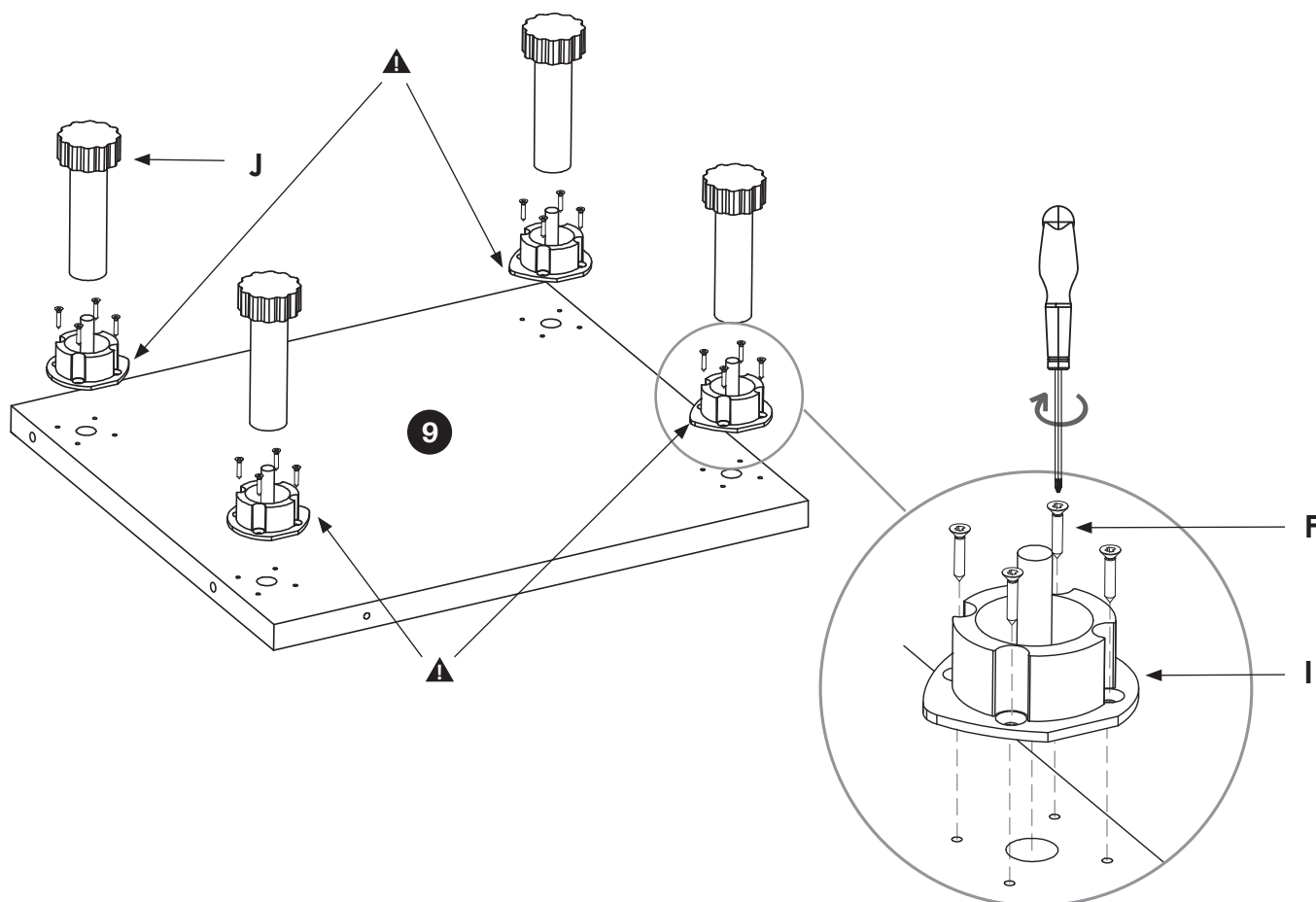

⚠ Les embases doivent être positionnées avec la pointe vers l'intérieur de la tablette.

28.

QUINCAILLERIE

Sachet n°827

K	excentrique	x4
---	-------------	----

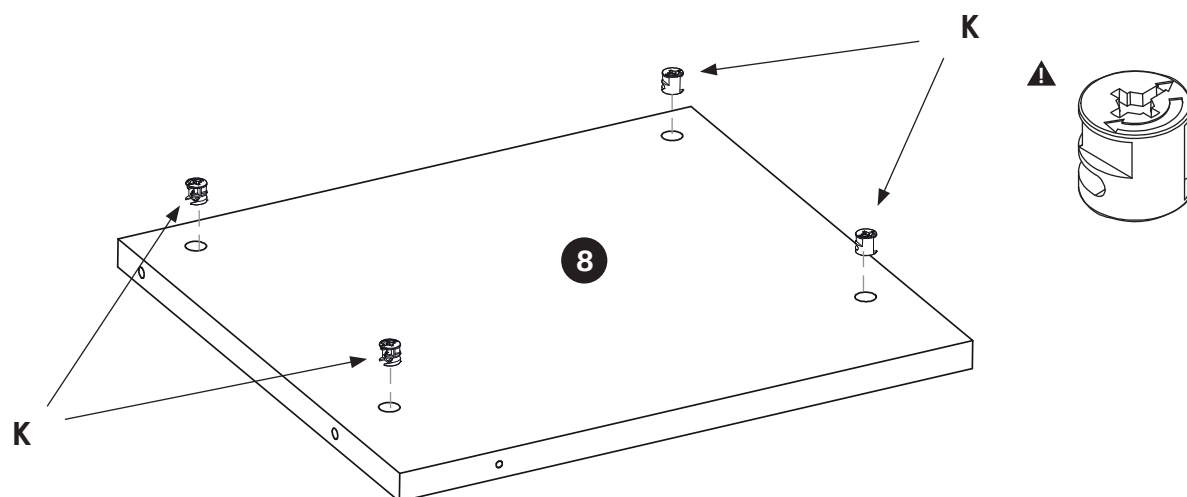

⚠ La flèche des excentriques est orientée vers l'extérieur de la tablette.

29.

OUTILS

maillet

QUINCAILLERIE

Sachet n°827

1/2

K	excentrique	x2
---	-------------	----

Sachet n°847

L	boîtier	x2
---	---------	----

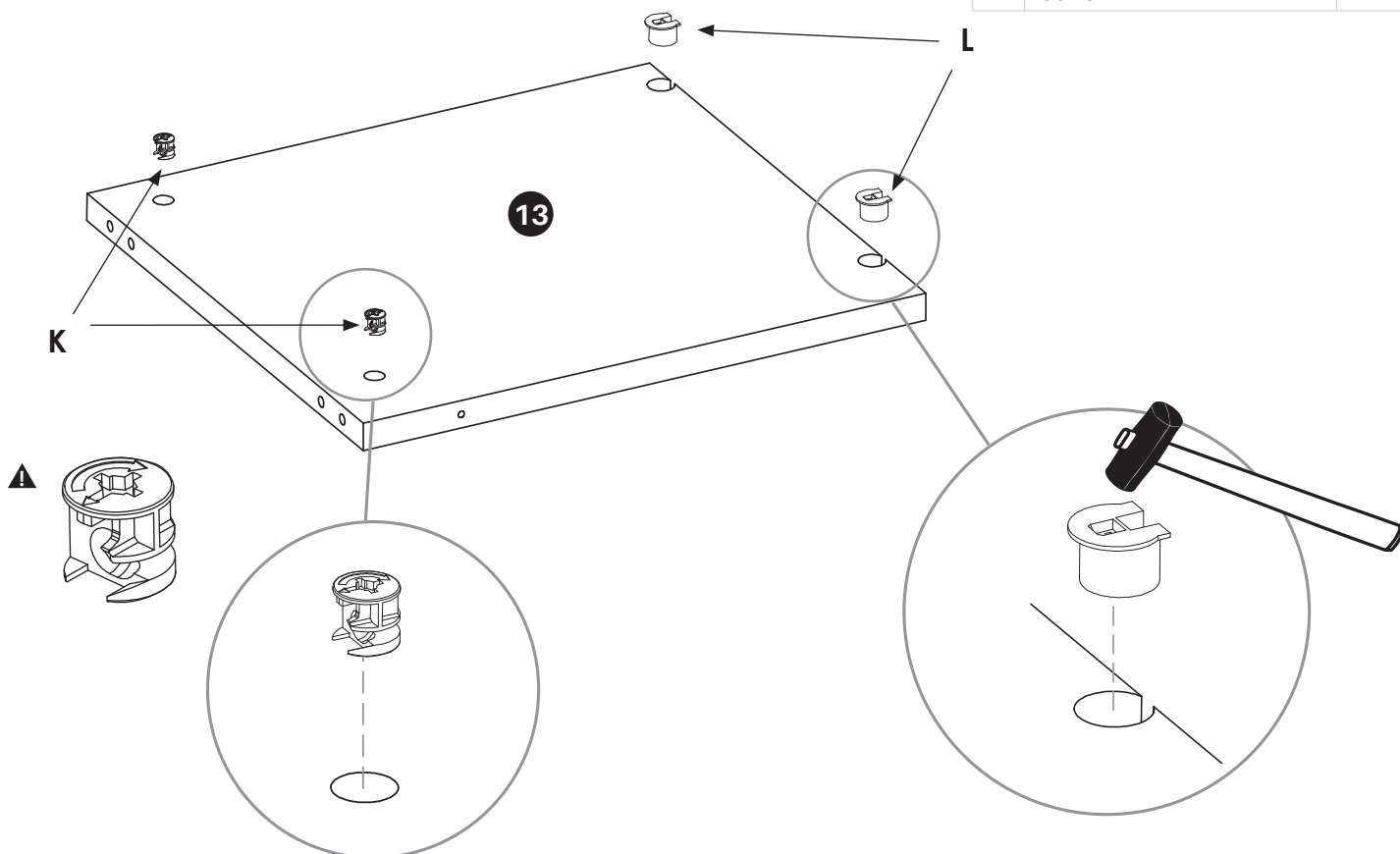

⚠ La flèche des excentriques est orientée vers l'extérieur de la tablette.

30.

Réaliser cette étape à proximité de l'ensemble préalablement monté, afin de limiter les déplacements à l'étape 31.

OUTILS

tournevis



clé 6 pans

QUINCAILLERIE

Sacnet n°832

S

vis

x3

Dans le sacnet **832**, il restera 3 vis non utilisées.

ÉTAPE 1

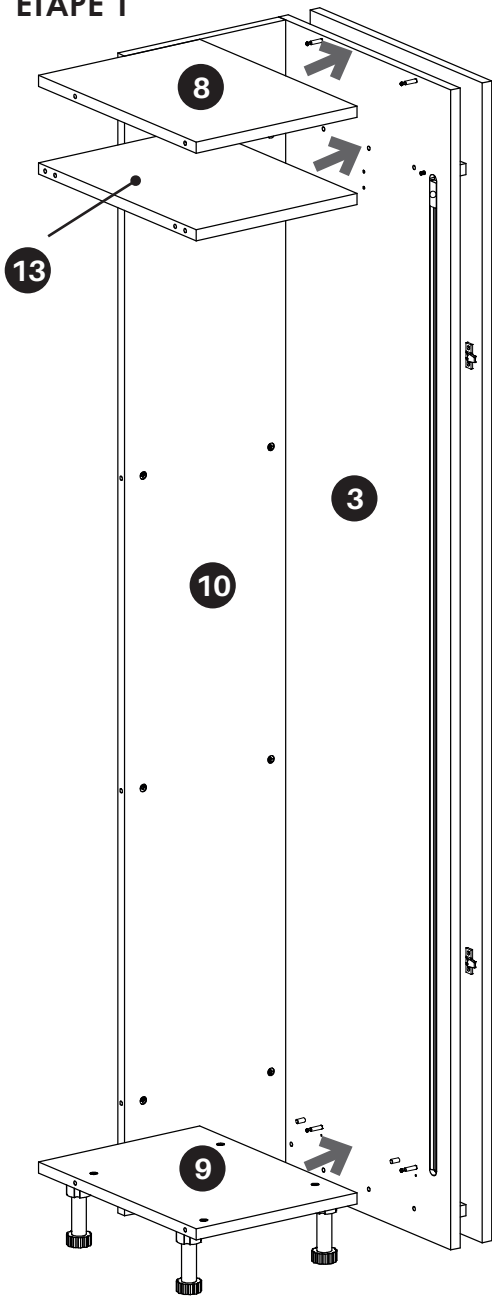

ÉTAPE 3

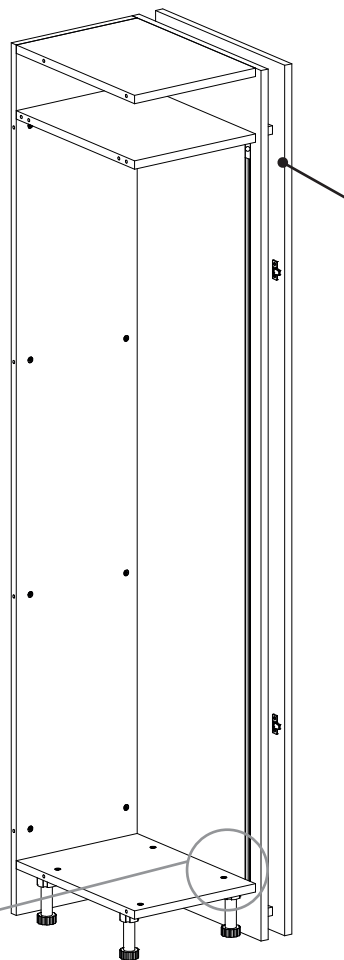
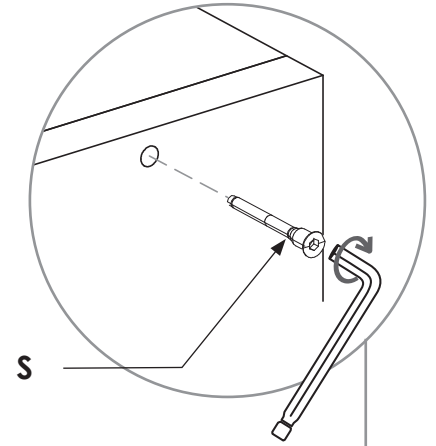

VUE DE FACE

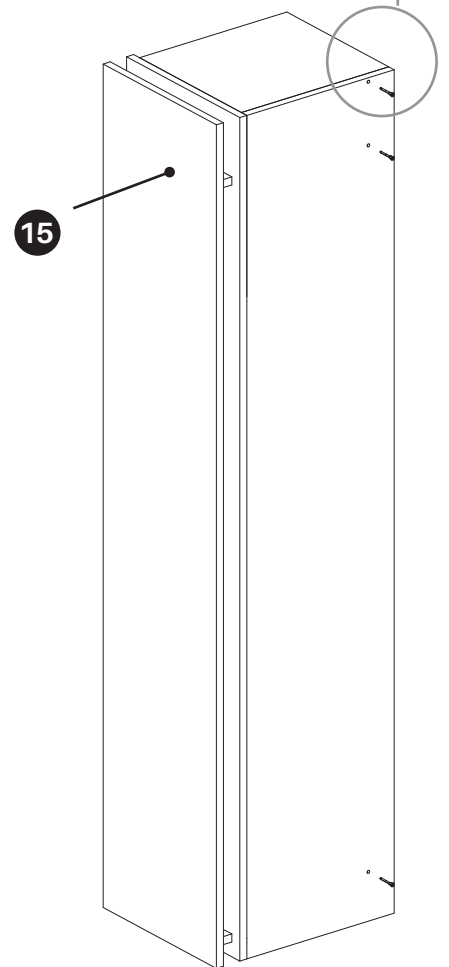

VUE DE DOS

ÉTAPE 2

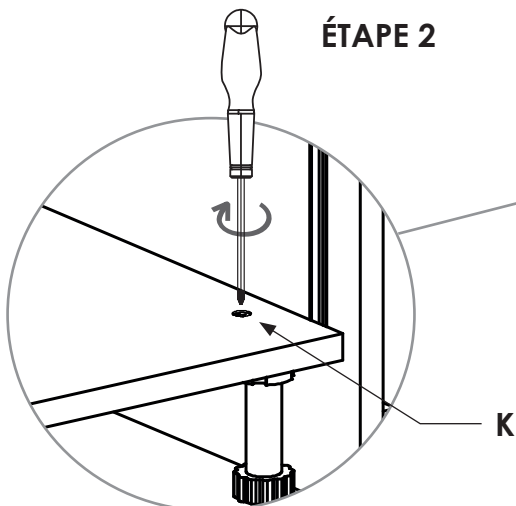

31.

OUTILS

tournevis



ÉTAPE 1

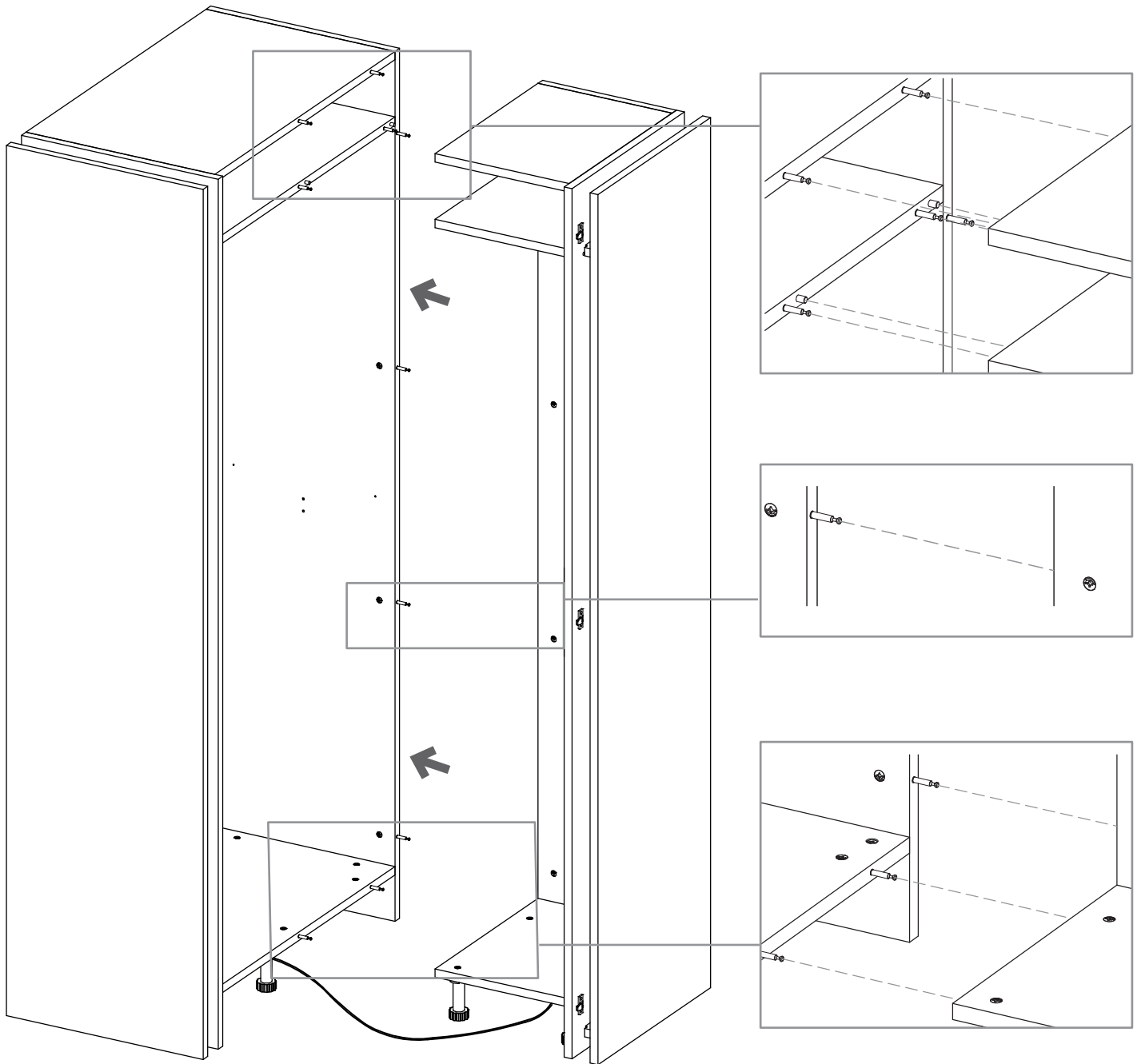

ÉTAPE 2

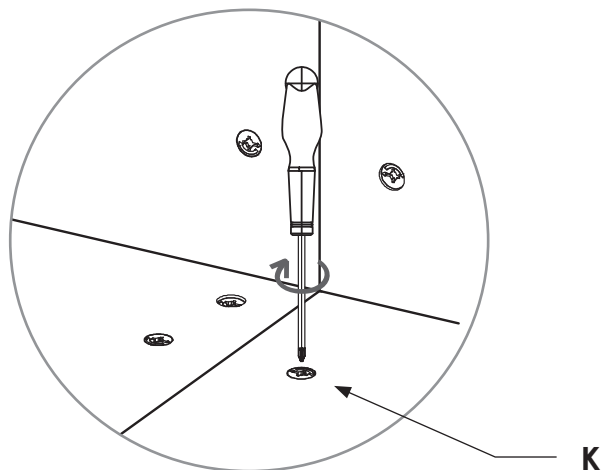

32.

OUTILS

tournevis



QUINCAILLERIE

	Sachet n°801	x2
G	clip de plinthe	x4
H	support clip de plinthe	x4
F	vis	x8

ÉTAPE 1

x2

23 et 24

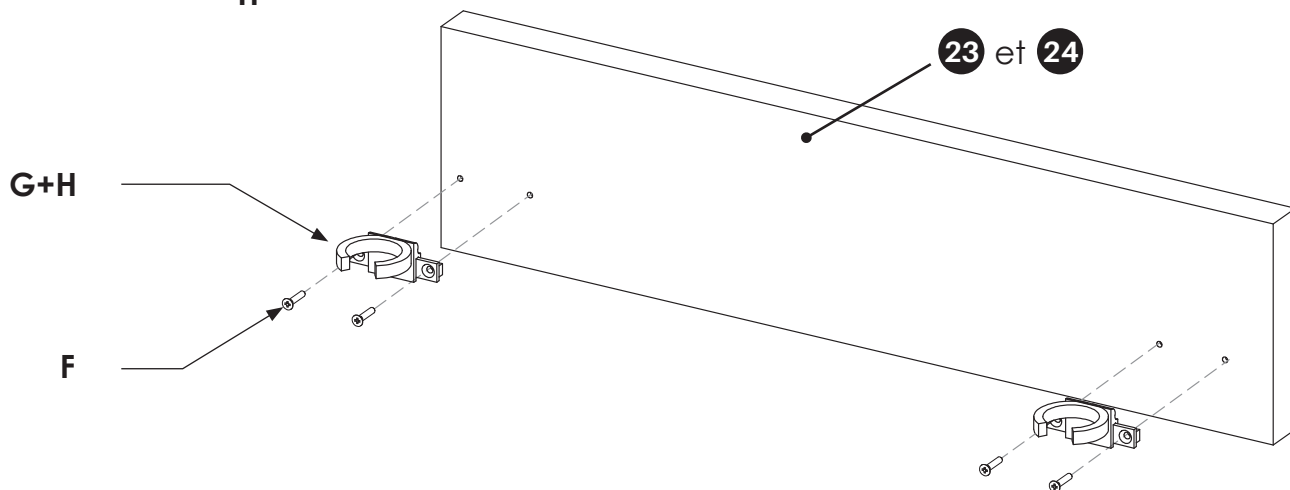
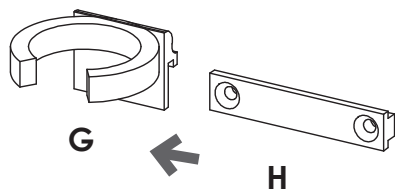

ÉTAPE 2

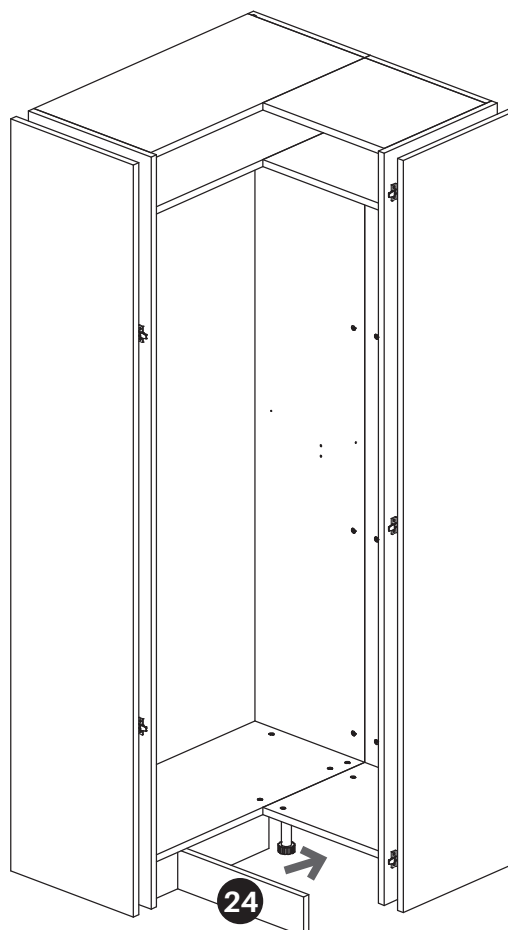
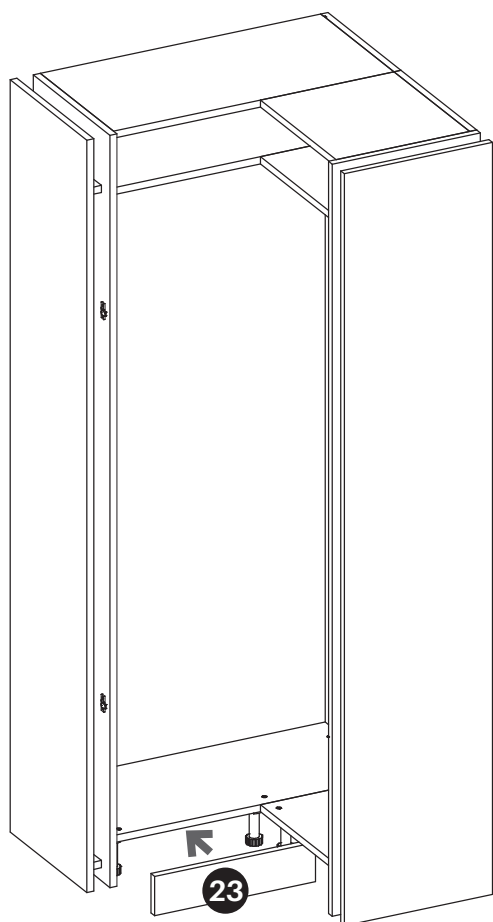

33.

OUTILS

tournevis



QUINCAILLERIE

Sachet n°828

P	support tringle	x2
F	vis	x2

⚠ Les vis sont à visser sans pré-perçage préalable.

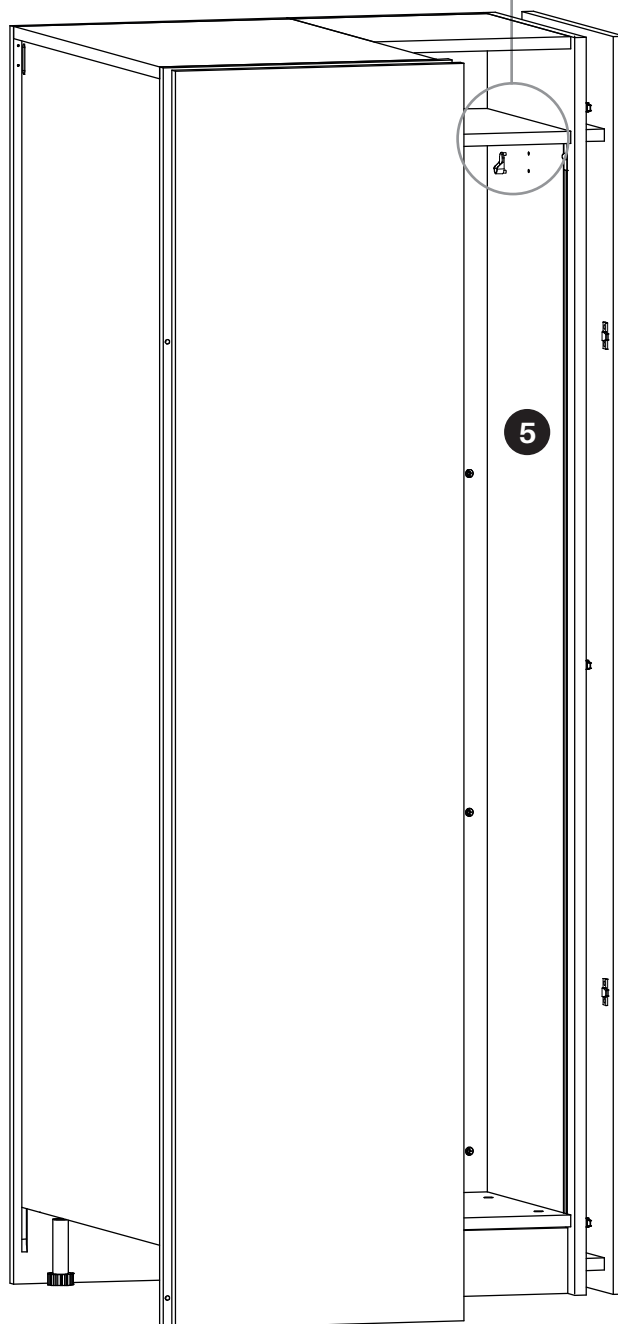
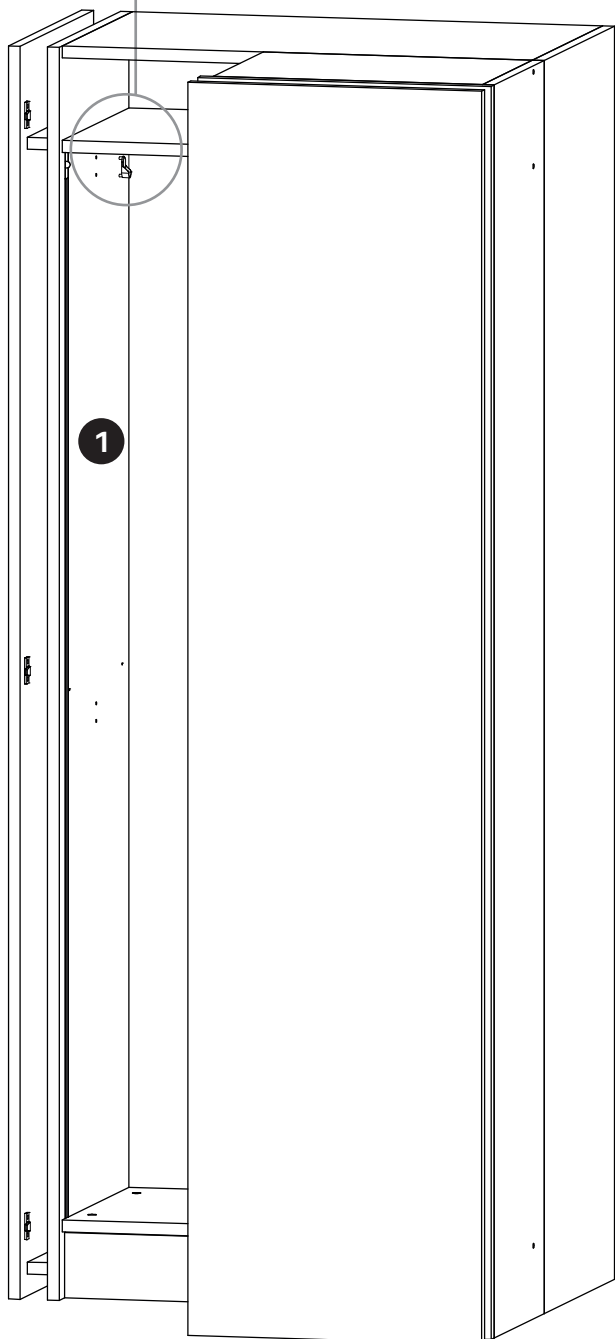
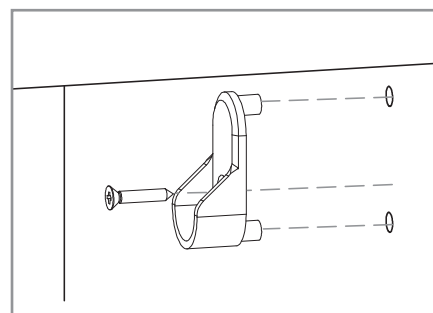
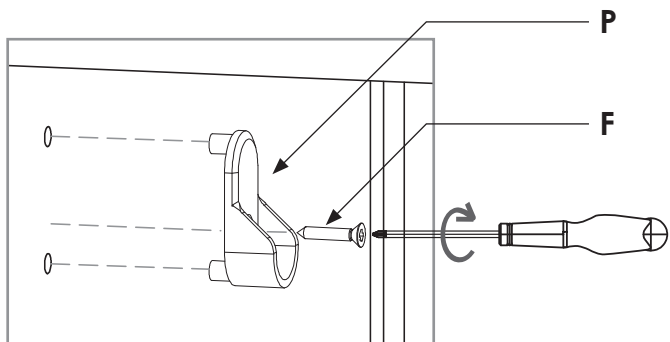

34.

OUTILS

tournevis



QUINCAILLERIE

Sachet n°850

U	coude de jonction	x1
V	support sous tablette	x1
F	vis	x2

ÉTAPE 1

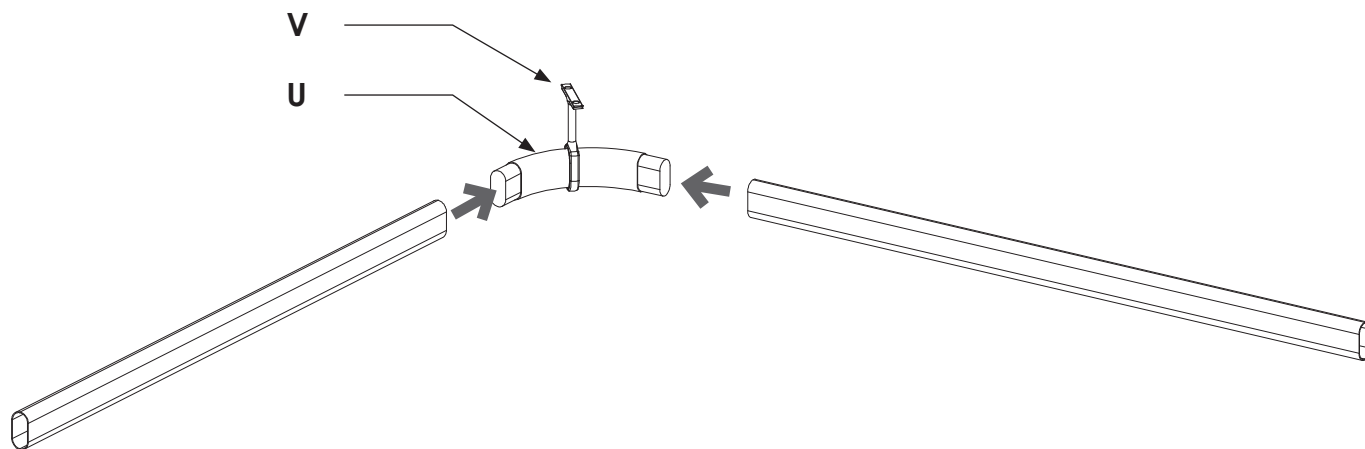

ÉTAPE 2

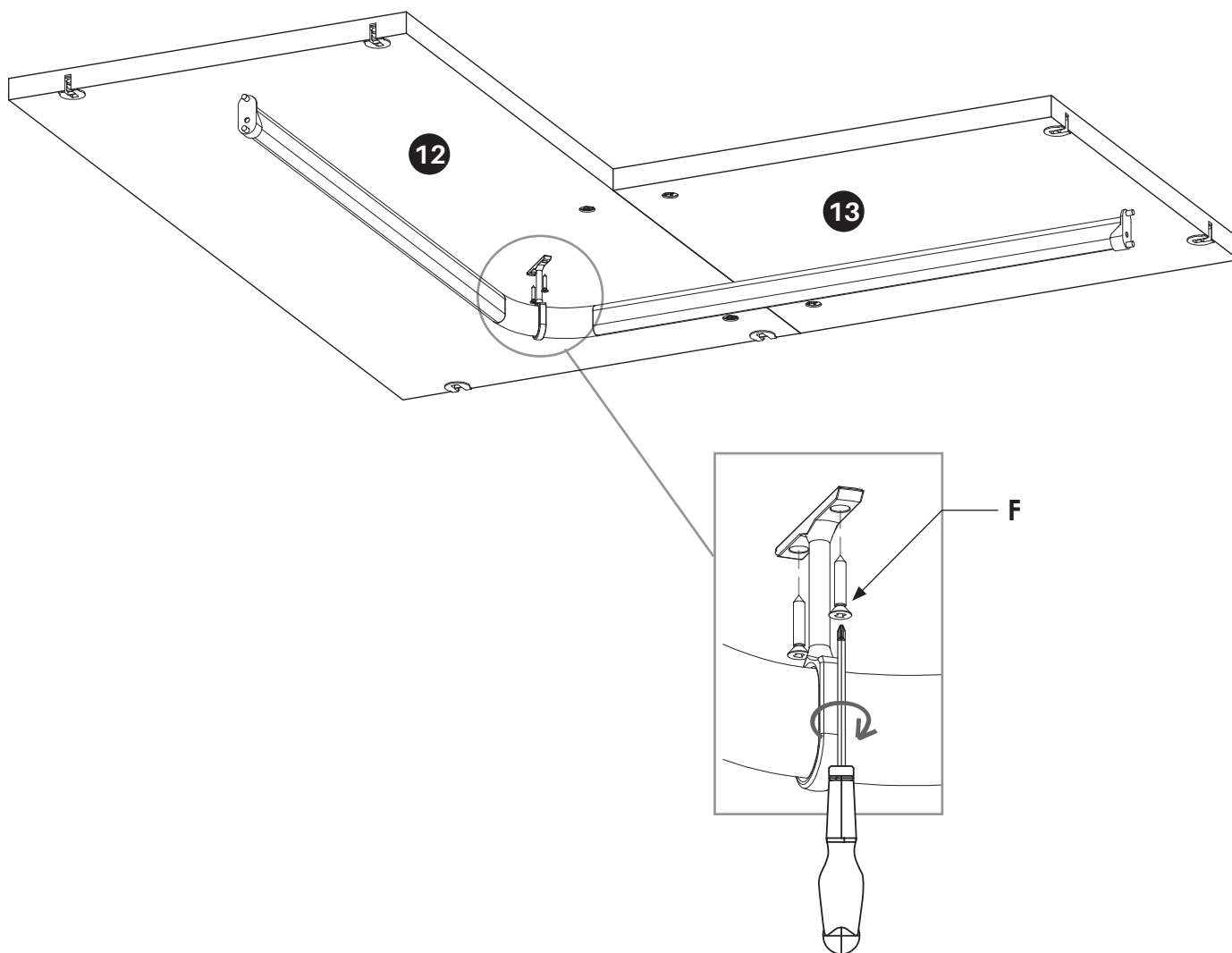

35.

OUTILS

maillet

tournevis



QUINCAILLERIE

Sachet n°804

L

boitier

x4

Sachet n°804

M

goujon

x4

ÉTAPE 1

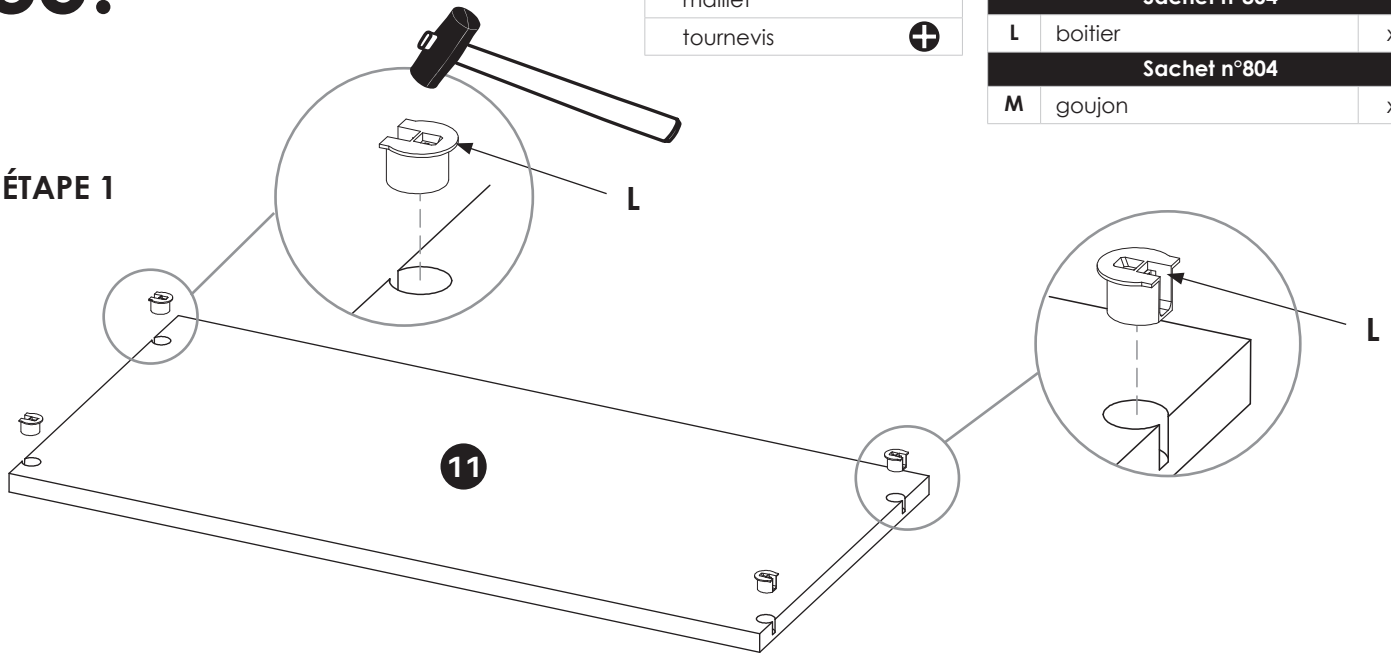

ÉTAPE 2 : Répéter les étapes 17. et 18.

36.

OUTILS

tournevis



QUINCAILLERIE

Sachet n°828

P

support tringle

x2

F

vis

x2

Répéter l'étape 33. dans les joues 1 et 5 pour fixer la tringle droite sous la tablette 11.

⚠ Les vis sont à visser sans pré-perçage préalable.

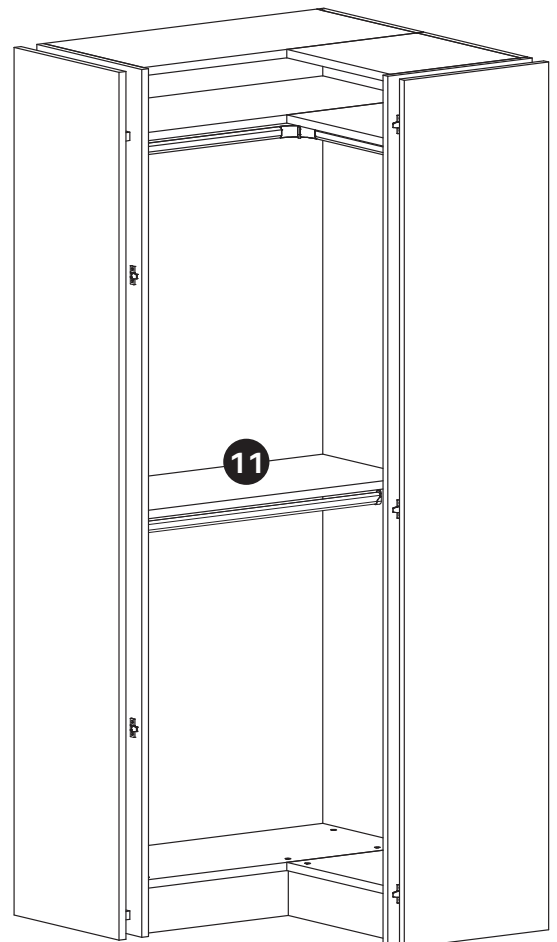
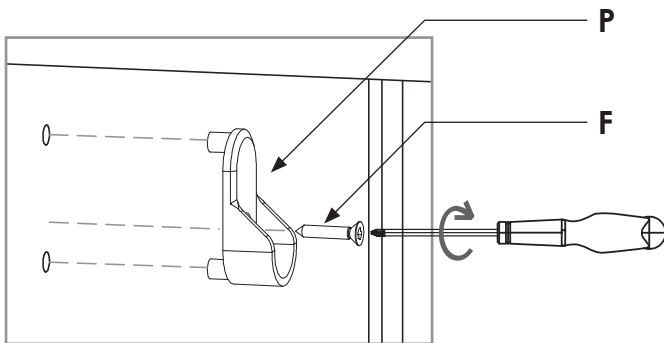

Si **MEUBLE D'ANGLE** utilisé seul : passer à l'étape **37a**.

Si **MEUBLE D'ANGLE** utilisé avec un Soleo à droite et/ou à gauche : passer à l'étape **37b**.

37a.

OUTILS

tournevis



QUINCAILLERIE

Sachet n°834

x2

Q ferrure femelle

x10

F vis

x20

ÉTAPE 1

x2

2 et 16 : largeur 100 mm

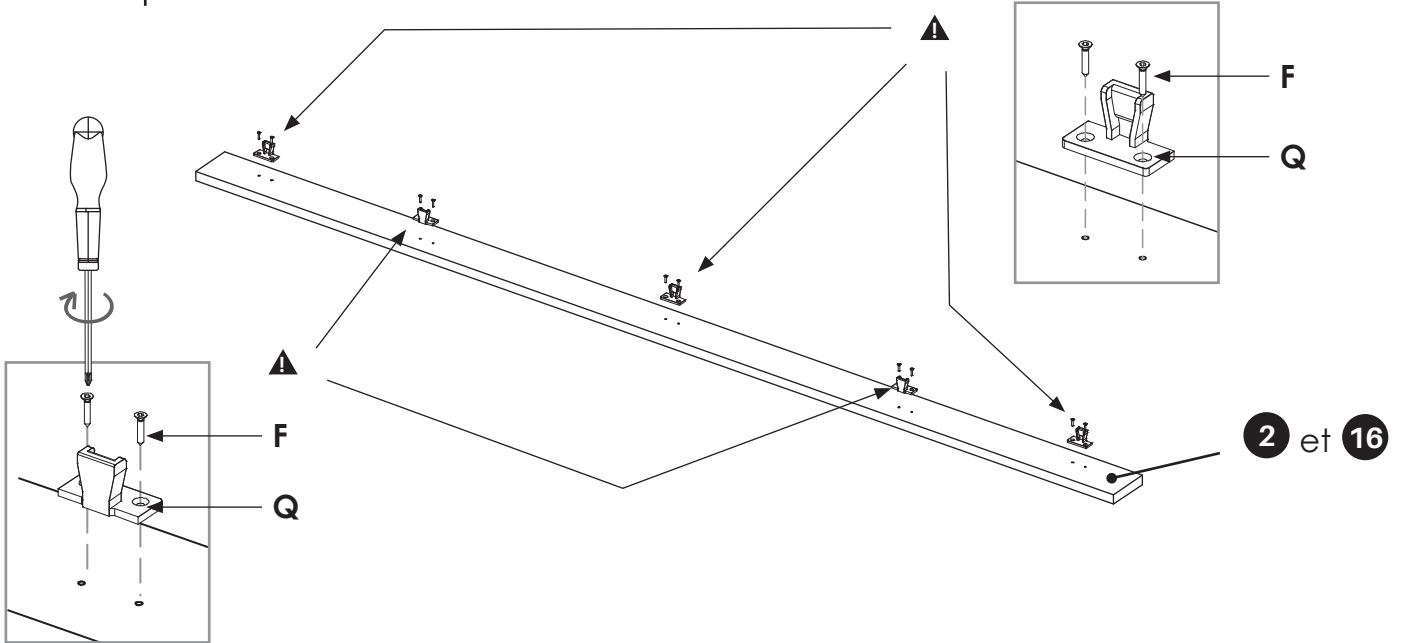

ÉTAPE 2 : Positionner les montants 2 et 16

VUE DE DESSUS

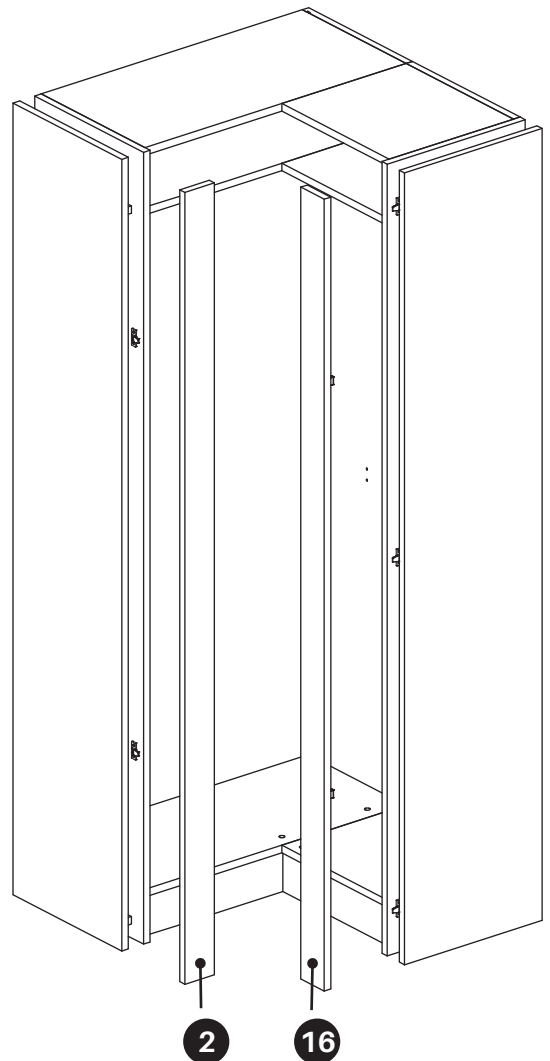
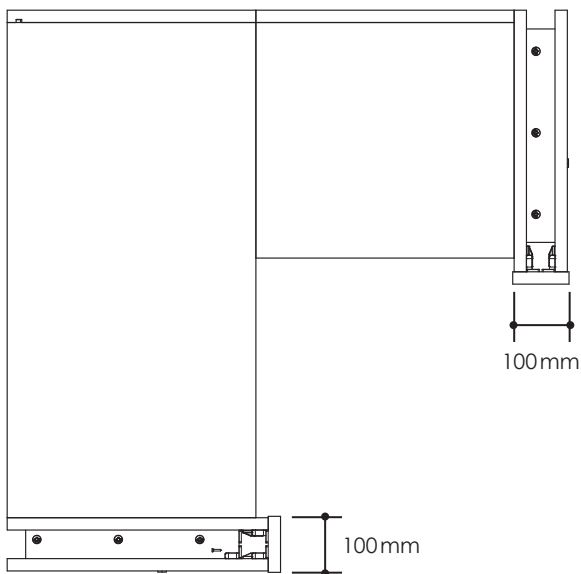

37b.

OUTILS

tournevis



QUINCAILLERIE

Sacnet n°834		x2
Q	ferrure femelle	x10
F	vis	x20

Monter l'espace d'angle en premier, à l'exception des montants larges.

ÉTAPE 1 : 21 et 22 : largeur 122 mm

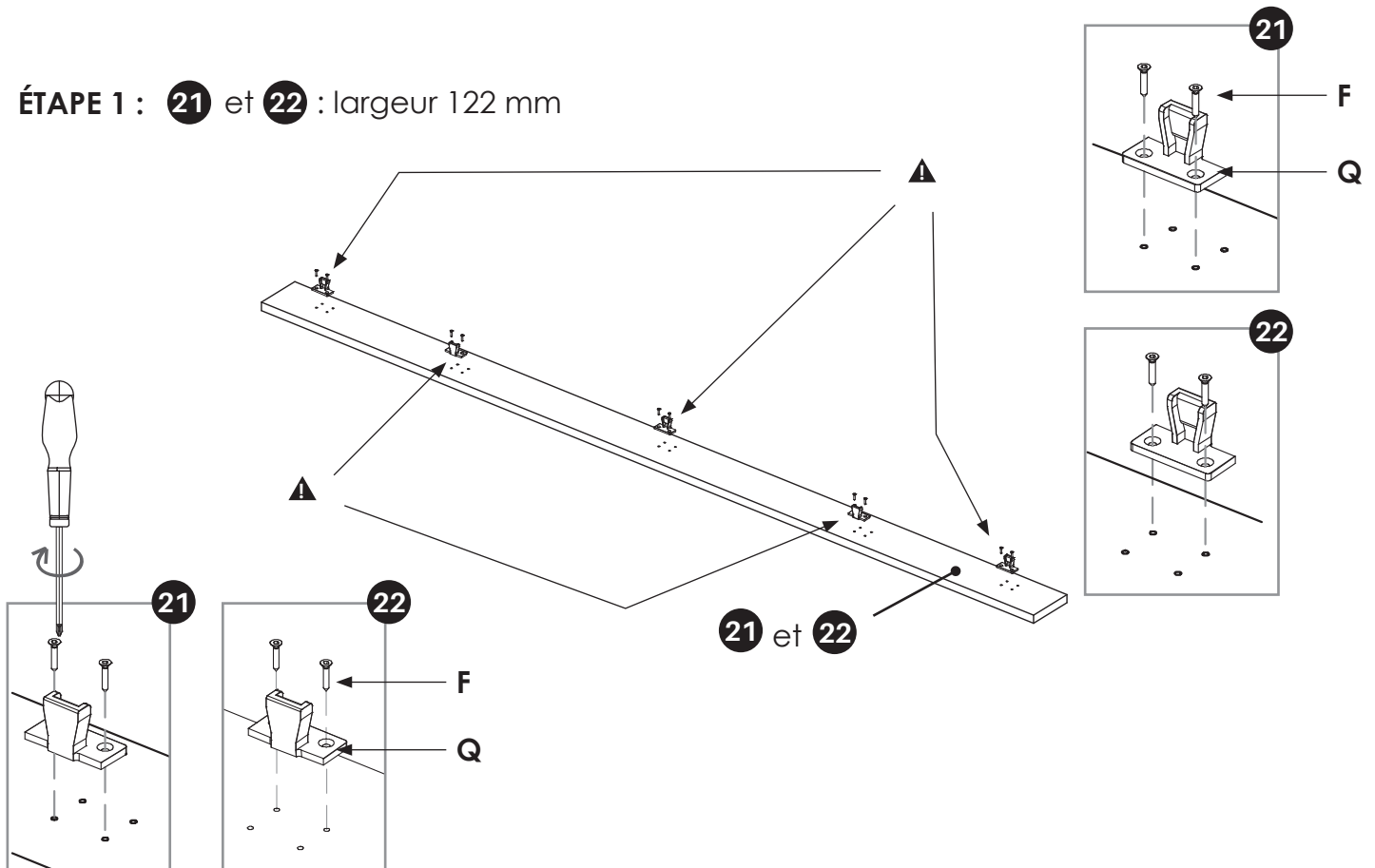

ÉTAPE 2 : Positionner les montants 21 et 22 afin que ce(s) dernier(s) recouvre(nt) la/les joue(s) externe(s) du/des Soleo.

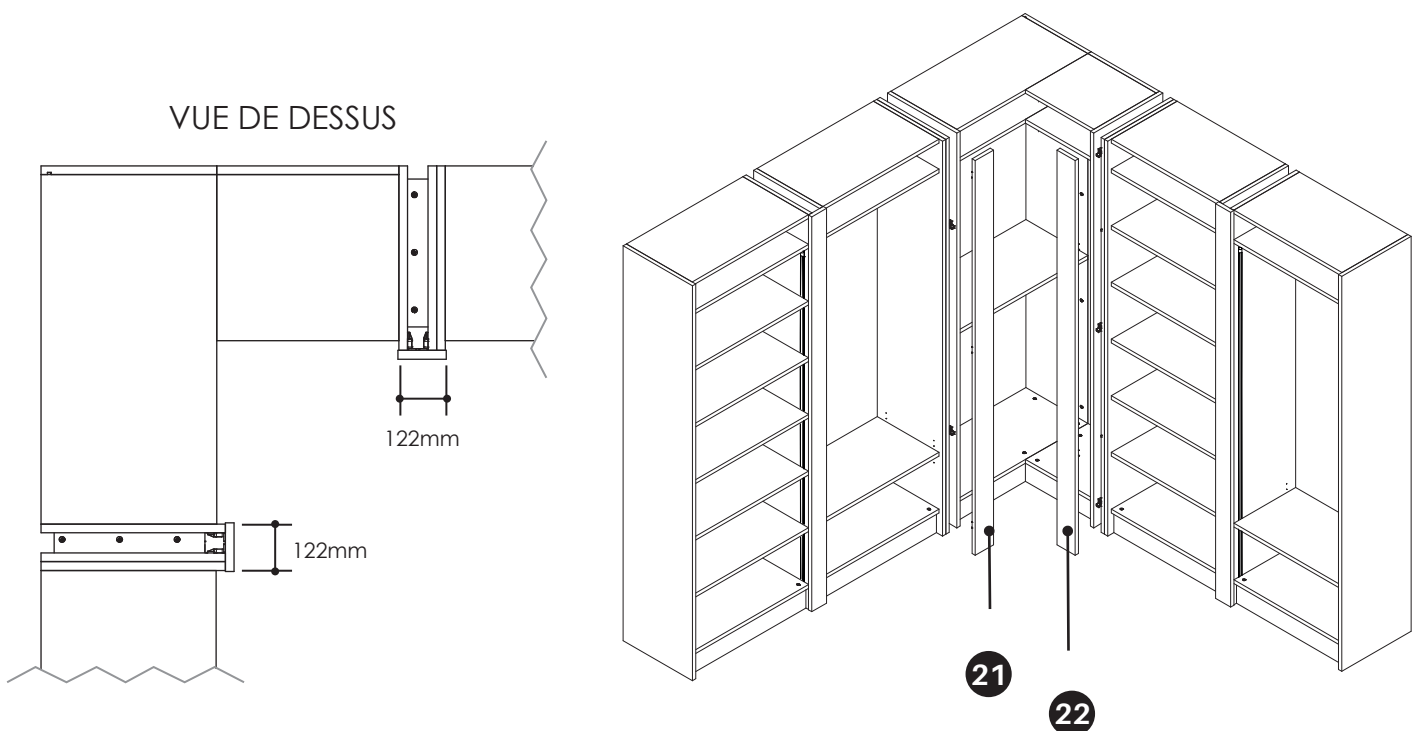

KAZED À VOTRE ÉCOUTE



05 49 25 40 29



SAS KAZED
45 allée des Grands Champs
CS90066
79260 La Crèche



www.kazed.fr
www.kazed.store

 **Kazed**

